

SUMITOMO

SH130-6

- Engine Rated Power (Net): 70.9 kW · 96.4 PS
- Operating Weight:
 - SH130(LC)-6 12,400~13,900 kg
- Bucket: ISO/SAE/PCSA Heaped: 0.24~0.65 m³



HYDRAULIC EXCAVATOR FOR REAL PERFORMANCE

SUMITOMO



**SUMITOMO (S.H.I.)
CONSTRUCTION MACHINERY CO., LTD.**

731-1 Naganumahara-cho, Inage-ku, Chiba, 263-0001 Japan
For further information please contact: Phone : +81-43-420-1829 Facsimile : +81-43-420-1907

We are constantly improving our products and therefore reserve the right to change designs and specifications without notice.
Illustrations may include optional equipment and accessories and may not include all standard equipment.

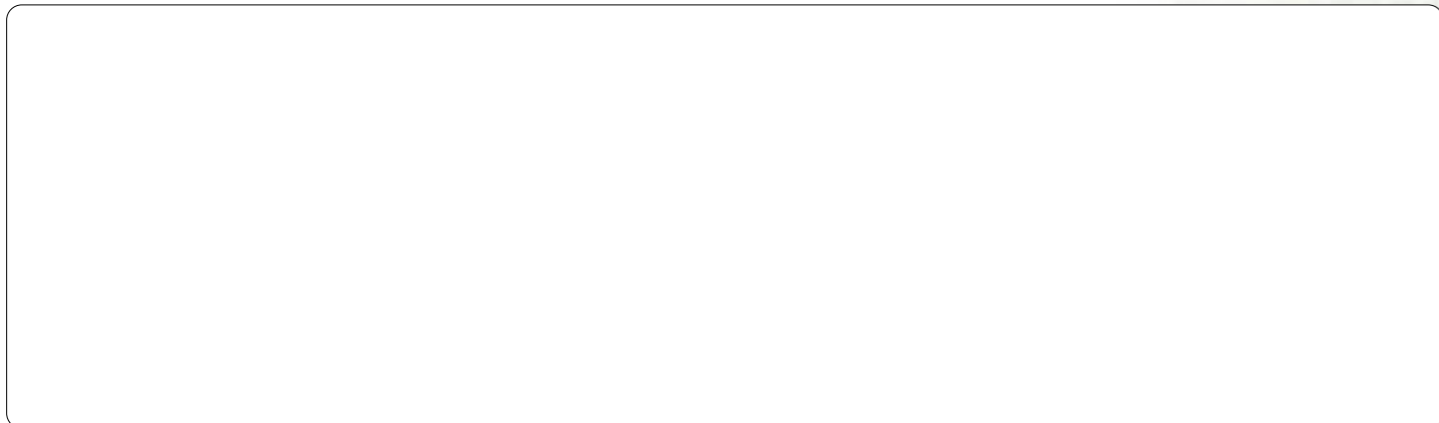

Performance Refined. Evolution Defined.

Engine and Hydraulics 04-07

- New Generation Engine System "SPACE 5+"
- New Hydraulic System "SIH:S+"
- SUMITOMO Fuel Efficiency Technology
- Dramatically Increased Productivity

Durability and Maintenance 08-11

- High Rigidity Attachments
- EMS
- Ground Level Maintenance

Safety and Operator Comfort 12-17

- Stylish and Spacious Cabin
- High-Definition Full Colour LCD Monitor

Specifications 18-26

ENGINEERED IN JAPAN

The world knows that Japanese designed and engineered products represent the highest quality, especially for Industrial Products. The hydraulic excavator is no exception when a totally integrated concept is required in design work involving key components, manufacturing engineering, and product quality assurance in the factory.

SUMITOMO hydraulic excavators are designed and manufactured today to meet the global demands of our many customers with the concept of Performance, Reliability, and Fuel Efficiency foremost in our minds. This proven Japanese technology and quality gives SUMITOMO excavator customers total peace of mind and provide a complete solution for the demands of the construction industry.



**Performance Refined.
Evolution Defined.**

New Engine System **SPACE 5+ PLUS** + New Hydraulic System **SIH:S+ PLUS** = **6% Reduction in Fuel Consumption**
(as compared with SH130-5 [H mode])

New Generation Engine System "SPACE 5+"

The new engine system optimises fuel efficiency and environmental performance via the advanced common rail fuel injection system, cooled EGR system, and turbocharger. At the same time, excellent response times are achieved.



Engine and Hydraulics

SH130-6 has achieved a 6% reduction in fuel consumption in comparison with our DASH 5 series, by fusing the new generation engine system "SPACE 5+" and the new hydraulic system "SIH:S+", further refining fuel efficiency. At the same time the newly developed ISUZU engine, contributes greatly to the environment.

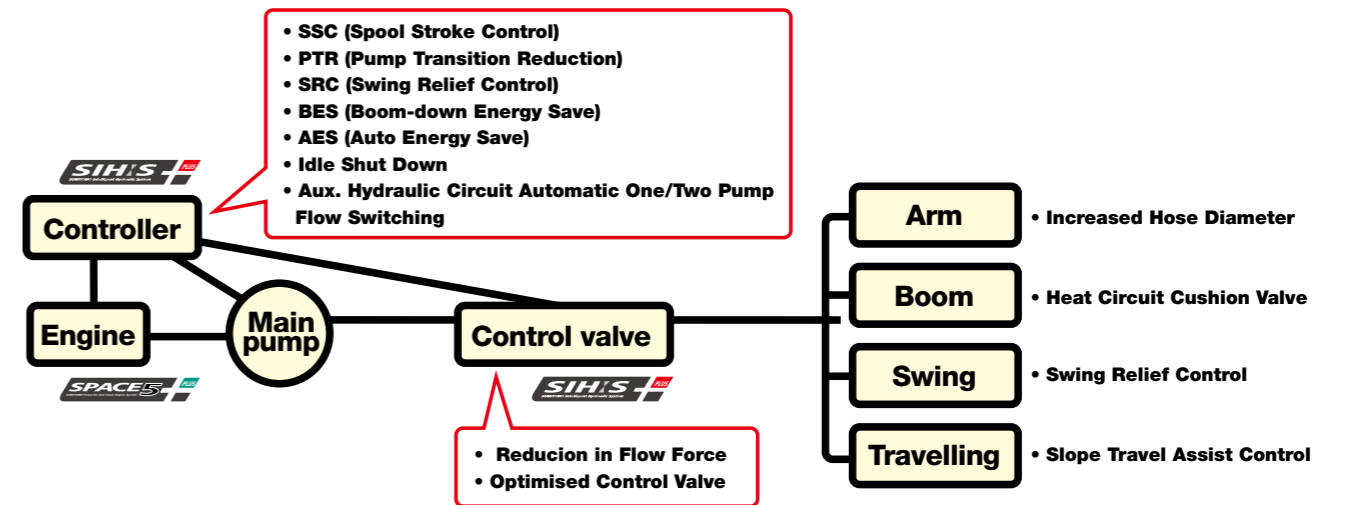

Mode Selection by Throttle SUMITOMO UNIQUE DESIGN

There are three working modes available: SP (Super Power) for heavy duty applications, H (Heavy) for normal working conditions, A (Auto) for a wide range of operations.



Further Improvement of Fuel Consumption

The new technology has improved operations and reduced fuel consumption on each working mode.

- SP mode **2% reduction in fuel consumption**
- H mode **6% reduction in fuel consumption**
- A mode **3% reduction in fuel consumption**
(as compared with SH130-5)

*Fuel consumption may vary from time to time depending on site and working conditions, operator skill and other circumstances.

ECO Gauge Showing Low Energy Operation

The energy saving conditions can be seen at a glance, as well as the fuel consumption indicator shown on the monitor.



SUMITOMO Technology for Fuel Efficiency

- **SSC (Spool Stroke Control)** SUMITOMO UNIQUE DESIGN
Reduces engine load upon heavy duty operation.
- **BES (Boom-down Energy Save)** SUMITOMO UNIQUE DESIGN
Lowers engine speed upon boom-down and swing operation which does not require large oil flow.
- **AES (Auto Energy Save)** SUMITOMO UNIQUE DESIGN
Lowers engine speed accordingly when low engine load is sensed.
- **PTR (Pump Transition Reduction)**
Decreases engine load when the pump flow requirement is reduced upon abrupt pump load.
- **Idle Shut Down & Auto Idle**
Upon activation, idle shut down automatically shuts the engine down when the machine is not in operation for set amount of time. Auto Idle is also available, which makes the engine begin idling approximately five seconds after the operation levers are in neutral position.





**Performance Refined.
Evolution Defined.**

Engine and Hydraulics



SUMITOMO's original technology Spool Stroke Control (SSC), perfectly matches the engine and hydraulic power, and further improves the operational speed whilst maintaining smooth control of the machine.

Work Efficiency Drastically Increased **SUMITOMO UNIQUE DESIGN**

Spool Stroke Control (SSC) variably controls spool port flow rate, depending on the condition of operation. Improved power, speed, and smoother controls mean that work efficiency is dramatically increased.

2% Faster Cycle Time (SP mode)

Speed increase by 2% in cycle time has been achieved, giving further advance in productivity (as compared with 130-5 [SP mode]).

Real Digging Power

The true digging force can not be expressed by a maximum digging power figure listed in sales brochures. With an improved hydraulic system and with a large arm cylinder, the arm-in motion speed slowdown is minimised. The digging power when combined with the attachment speed in motion convert to the operator's "Real Digging Power".

Automatic Power Boost

The digging power increases automatically in quick response to the working conditions during heavy-duty digging work. This is a design unique to SUMITOMO, and continues for eight seconds (SP/H mode).

Speed and Power, Dramatically Increases Productivity

- SP mode **2%** faster cycle time
- A mode **2%** faster cycle time (as compared with SH130-5)

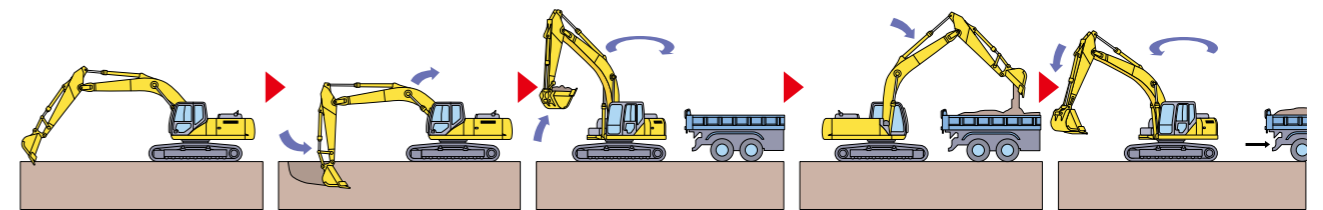

*Based on SUMITOMO's testing condition and results.

Operating Condition Easily Viewable on Display

Various control such as working modes and auxiliary hydraulic setting can be easily selected by the universally designed switch panel, and what's being selected can be easily viewed on the 7" wide monitor.





Durability and Maintenance

High Rigidity Attachments

The structure of the boom and arm has been further improved, ensuring strength and durability. In addition, high strength castings are used for the boom base and arm end, improving reliability.

• Boom

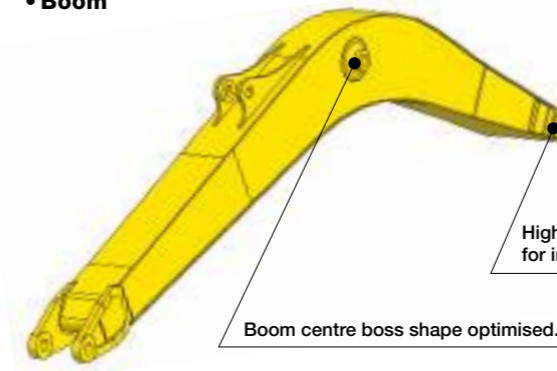

• Arm

High strength castings used for increased reliability.

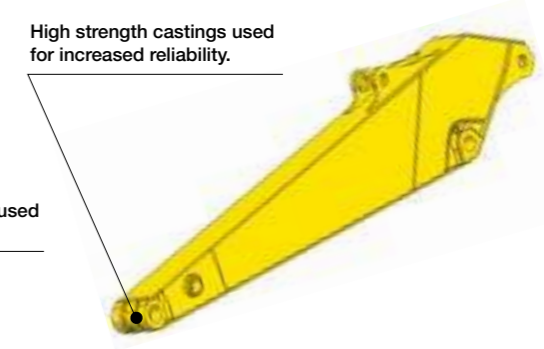

EMS (Easy Maintenance System) as Standard

SUMITOMO's EMS keeps the pins and bushes fully lubricated at all times and prevents rattling. This system significantly extends the service life of the pins and bushes.

The lubrication interval around the bucket is 250 hours, and for the other sections is 1,000 hours, keeping the joints lubricated for a long time and extending the service life of parts by reducing abrasion and rattling.

- **Bucket greasing interval: 250 hours**
- **Greasing interval for other sections: 1,000 hours**

* The greasing interval depends on the working conditions.



➡ Sections equipped with steel EMS bushing
➡ Sections equipped with EMS bushing

■ EMS bushing

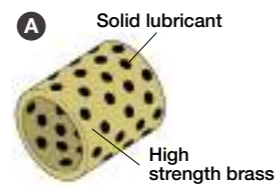

A A solid lubricant embedded in high strength brass forms a layer on the bushing surface to prevent contact between metals, maintaining an excellent lubricated state to reduce abrasion of joints.

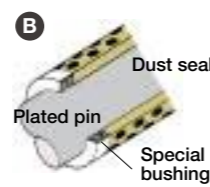

B The surface of the pin is plated to increase the surface hardness and improve the wear resistance accordingly.

■ Steel EMS bushing



Steel EMS is installed around the bucket

Precautionary use of EMS

- ① Grease is enclosed, however greasing is necessary every 1000 hours or six months depending on the level of dusting conditions.
- ② Greasing is also necessary after any components have been submerged underwater for prolonged periods.
- ③ Greasing is also recommended after use with hydraulic breakers, crushers or other high impact attachments such as Rock Saws etc.
- ④ Bucket pins should be cleaned thoroughly when removing or attaching new buckets.

Bucket

A one-piece wear plate covers the weld section to increase the wear life of the bucket.

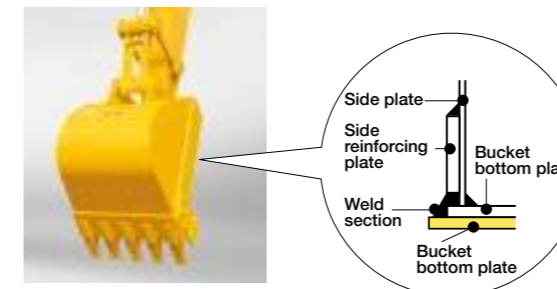

High Rigidity Swing Frame

The swing frame has been strengthened to support the new ROPS cabin, as well as to increase durability.

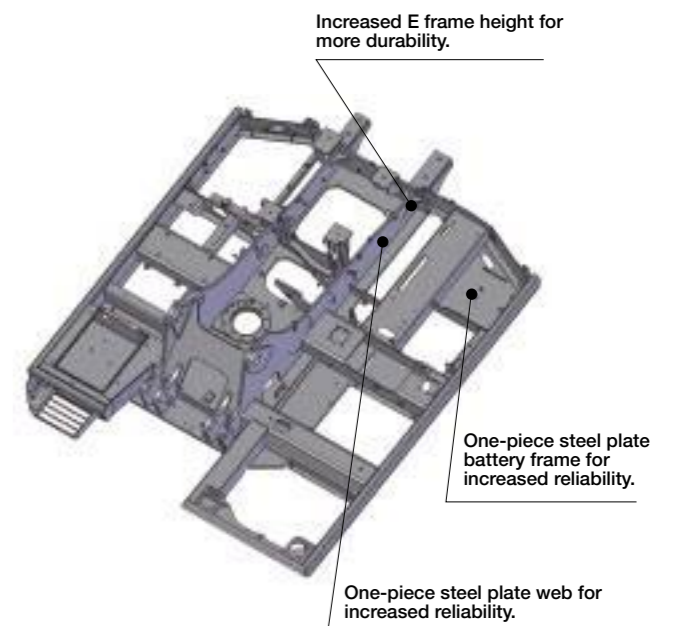

High Rigidity Undercarriage

For improved mobility, the track system has been strengthened ensuring longer wear life, performance, and improved reliability.

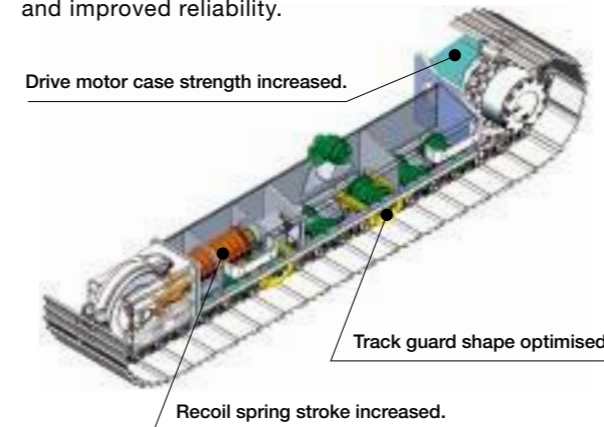

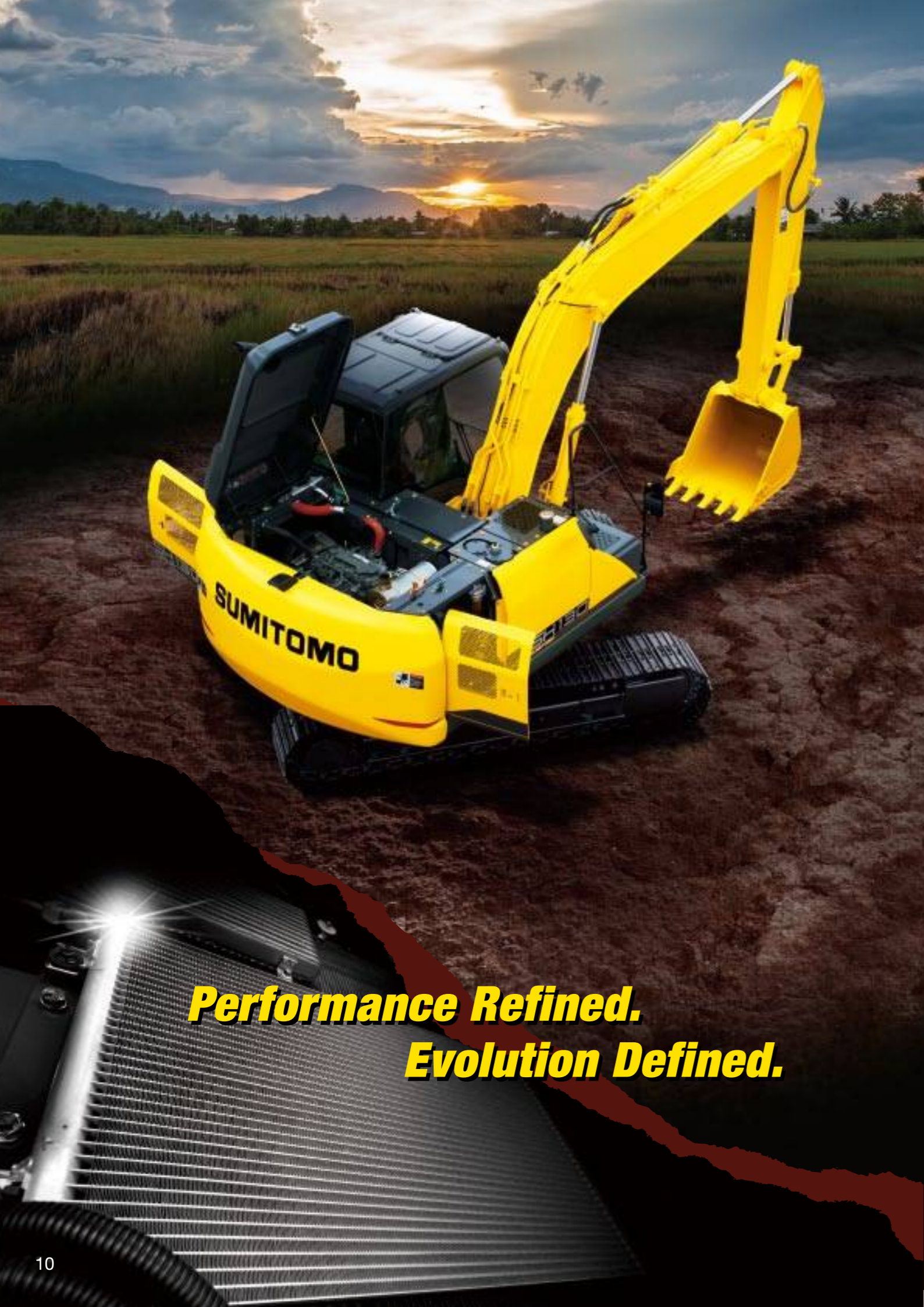

**Performance Refined.
Evolution Defined.**

Durability and Maintenance

Serviceability and durability are also important points of machine performance. Ground level access to the engine area makes daily maintenance extremely straightforward. Reliability has been further enhanced by increasing cooling capability and durability.

Ground Level Access to Engine Area Improves Preventative Maintenance

Parts cleaning and maintenance are possible from the ground without climbing onto the upper structure of the excavator body.

- **Increased Cooling Capability**

With the larger radiator and oil cooler, cooling capacity is increased, thus improving reliability. In addition, cleaning of the dust-proof net is simplified.

- **Easy Filter Replacement**

A fuel prefilter and clogging sensor to the main fuel filter are provided as standard equipment to reduce trouble due to fuel clogging. In addition, the fuel and oil filters are installed at ground-accessible location to facilitate replacement.

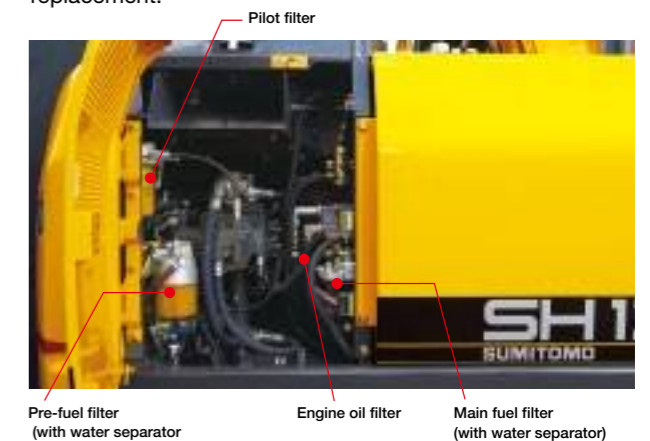
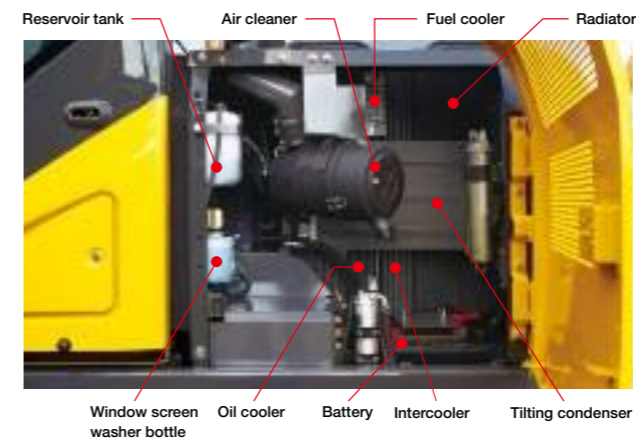

High-Performance Return Filter

The hydraulic oil change interval is 5,000 hours, and the return filter change interval is 2,000 hours. One high performance return filter keeps the same level of filtering as a nephron.



- **Hydraulic oil change: 5,000 hours**

- **Life of filter: 2,000 hours**

* The oil and filter change interval varies by the working conditions.

Easy Access to A/C Filter

The air intake filter is located in a lockable compartment to make it easier to replace, and access to the inside cab filter has been simplified.



Fuse Box Location

The fuse box has been located in a separate compartment behind the seat, allowing easier access.



Cab Floor Mat SUMITOMO UNIQUE DESIGN

The washable floor mat has been redesigned for ease of removing and cleaning.



New Side Frame Shape

The cross-sectional shape has been redesigned to make cleaning easier.



**Performance Refined.
Evolution Defined.**

Safety and Operator Comfort

Planning for safety in the event of a roll accident, a new strengthened safety cabin has been provided. The reinforced cabin greatly increases the operator's safety.

Newly Designed Strengthened Safety Cabin

The optimised design and strengthened parts increase the overall cabin strength. Even if the shovel were to tip over, the safety of the operator is ensured by keeping cabin deformation to a minimum.

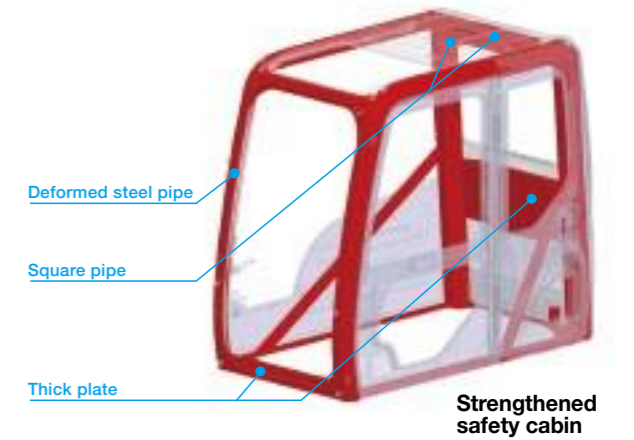

Wide View Increases Safety of Work

In addition to the wide front view, the upper view has been widened to enhance work safety.



Safe and Easy Entry into and Exit from the Cab

A large handrail for easy opening/closing of the door and increased floor space permit the operator to get in and out of the cab easily.



Super Comfortable Cab Mounts and Pressurised Cab

Fluid mounts that support the cab absorb shocks and vibrations effectively, improving ride comfort.

The cab also features a pressurised design to prevent dust from entering inside, giving operators greater comfort.

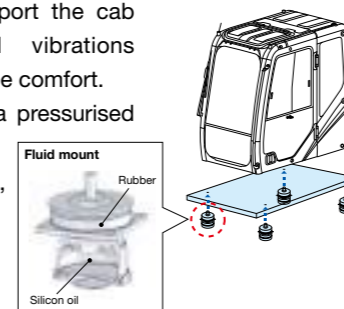

New OPG Level 2 Head Guard (option)

OPG Level 2 head guard is available as an option. The see-through grille has been redesigned for better protection and visibility.



Easy Access to the Upper Structure



New larger front-right step



Non-slip plate



ISO-compliant large handrail

Cab Front Guard (option)

The optional cab front guard increases security from flying debris during wrecking work or the like.



**Performance Refined.
Evolution Defined.**

Safety and Operator Comfort

The spacious cab on suspension mounts and reclining suspension seat help reduce operator fatigue and provide a relaxed environment.

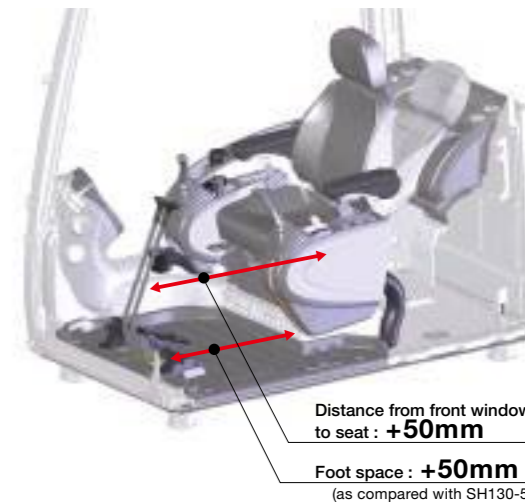

Stylish and Spacious Cab

Wide cab space and floor space ensure more comfortable operation. In addition to the tilting console that is adjustable in four steps vertically, the increased sliding distance ensures optimum working conditions. Moreover, in cab noise level has been reduced by 2dB (as compared with SH130-5).

Sophisticated Reclining Seat

The seat reclining system allows the operator to lay the seat flat and to rest on site without having to remove the headrest. The suspension seat eliminates vibration and fatigue. Air suspension is also available as option.



The highly water repellent seat covering is tough on dirt and water.



Air suspension (option)

Auxiliary Operation Pedal

The auxiliary operation pedal is lighter to depress and the pedal angle is adjustable.



Comfortable Equipment



Luggage space



Hot & cool box



Magazine rack

Automatic Air Conditioner

Fully automatic climate control is available through the eight vents, with an 8% stronger A/C unit, and a 24% improvement in airflow. (as compared with SH130-5)



Radio and Speaker with MP3 Jack

In addition to the AM/FM radio and dual speaker system with improved sound quality, auxiliary audio port is provided standard for devices such as MP3 players.



Lever Switches

One-touch idle, horn, radio mute, or one-touch wiper buttons are installed on the operation levers in consideration of improved operability while working.



Radio mute switch (left lever)



One-touch wiper switch (right lever)



Safety and Operator Comfort

To support the operator in the field, the DASH 6 incorporates a 7" wide full colour LCD monitor with numerous functions and universally designed switch panel. The cabin with enhanced operator comfort ensures a safe working environment.

Large High-Definition LCD Monitor

A new large high-definition full colour LCD monitor has been introduced with better visibility and a switch panel which is easy to operate. Added functionality such as ECO gauge showing parameter of energy saving, display of operation status and warning messages, provides accurate information which improves work efficiency and safety.

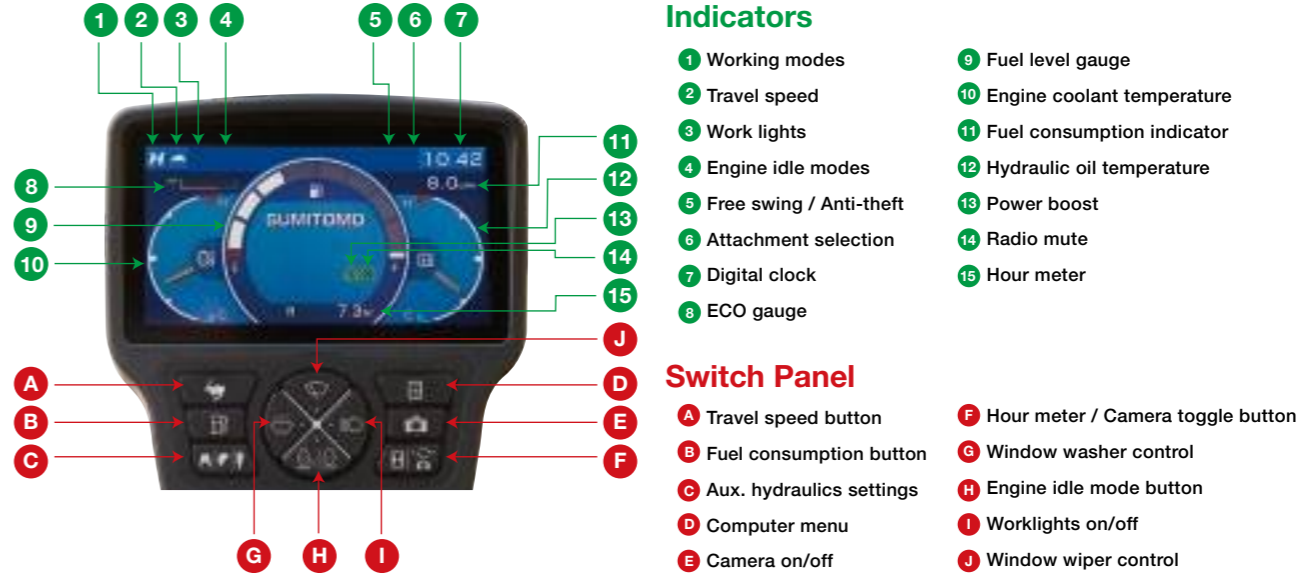

Rearview Camera (option)

With the rearview camera, the operator can view the image on the large LCD monitor. A side camera is available as option and up to two different images can be displayed on the monitor.



Rearview Mirror

The rearview mirrors reduce blind spots during operation. ISO compliant mirrors also available as option.



Specifications

SH130(LC)-6 Technical Data

Electronic-controlled engine of SPACE 5+ and SIH:S+ with New Hydraulic System Includes: three working modes (SP, H and A), one-touch/automatic idling system, automatic power-boost, speed assistance system, power-swing system.

Engine

SH130-6	
Model	ISUZU GJ-4JJ1X
Type	Water-cooled, 4-cycle diesel, 4-cylinder in line, high pressure common rail system (electric control), Turbocharger with air cooled intercooler.
Rated output	70.9 kW (96.4 PS)/2,000 min ⁻¹
Maximum torque	349 N·m at 1,600 min ⁻¹
Piston displacement	2.99 ltr
Bore and stroke	95.4 mm x 104.9 mm
Starting system	24 V electric motor starting
Alternator	24 V, 50 A
Fuel tank	260 ltr
Air filter	Double element

Hydraulic pumps

Two variable displacement axial piston pumps provide power for boom/arm/bucket, swing, and travel. One gear pump for pilot controls.

SH130-6	
Maximum oil flow	2 x 129 ltr/min
Pilot pump max.oil flow	20 ltr/min

Hydraulic motors

For travel: Two variable displacement axial piston motors.
For swing: One fixed displacement axial piston motor.

Relief valve settings

Boom/arm/bucket34.3 MPa (350 kgf/cm²)
Boom/arm/bucket36.3 MPa (370 kgf/cm²) with auto power-up
Swing circuit27.9 MPa (285 kgf/cm²)
Travel circuit34.3 MPa (350 kgf/cm²)

Control valve

With boom/arm holding valve
One 4-spool valve for right track travel, bucket, boom and arm acceleration
One 5-spool valve for left track travel, auxiliary, swing, boom acceleration and arm

Oil filtration

Return filter 6 microns
Pilot filter 8 microns
Suction filter 105 microns

Hydraulic cylinders

Cylinder	Q'ty	Bore x Rod Diameter x Stroke
Boom	2	105 mm x 70 mm x 961 mm
Arm	1	115 mm x 80 mm x 1108 mm
Bucket	1	95 mm x 65 mm x 881 mm

Double-acting, bolt-up type cylinder tube-end; hardened steel bushings
Installed in cylinder tube and rods ends.

Cabin & controls

The cabin is mounted on four fluid mountings. Features include safety glass front, rear and side windows, adjustable upholstered suspension seat with headrest and armrest, cigarette lighter, pop-up skylight window, and intermittent wiper with washer. Front window slides upward for storage and the lower front window is removable. Control levers are located in four positions tilting control consoles. Built-in type full-colour monitor display. Membrane switch on monitor display.

Swing

Planetary reduction powered by axial piston motor. The internal ring gear with grease cavity for pinion. Swing bearing is single-row shear type ball bearing. Dual stage relief valves for smooth swing deceleration and stops. Mechanical disc swing brake.

SH130-6	
Swing speed	0~14.1 min ⁻¹
Tail swing radius	2,130 mm
Swing torque	33.0 kN·m (3,365 kgf·m)

Undercarriage

X-style carbody is integrally welded for strength and durability. Grease cylinder track adjusters with shock absorbing springs. Undercarriage with lubricated rollers and idlers.

Type of shoe: sealed link shoe

Upper rollers -

Heat treated, mounted on steel bushings with leaded tin bronze casting, sealed for lifetime lubrication.

Lower rollers -

Heat treated, mounted on steel bushings with leaded tin bronze casting, sealed for lifetime lubrication.

Track adjustment -

Idler axles adjusted with grease cylinder integral with each side frame; adjustment yoke mechanism fitted with heavy duty recoil spring.

Number of rollers and shoes on each side

	SH130-6	SH130LC-6
Upper rollers	1	2
Lower rollers	7	7
Track shoes	43	46

Travel system

Two-speed independent hydrostatic system with compact axial motors for increased performance. Hydraulic motor powered output shaft coupled to a planetary reduction unit and track sprocket. All hydraulic components mounted within the width of side frame.

Travel speed can be selected by the switch panel on the monitor display. Hydraulically released disc parking brake is built into each motor.

		SH130-6	SH130LC-6
Travel speed	High	5.6 km/h	
	Low	3.4 km/h	
Drawbar pull		116 kN (11,829 kgf)	117 kN (11,931 kgf)

Lubricant & coolant capacity

SH130-6	
Hydraulic system	157 ltr
Hydraulic oil tank	82 ltr
Fuel tank	260 ltr
Cooling system	16.2 ltr
Final drive case (per side)	2.1 ltr
Swing drive case	2.2 ltr
Engine crank case	17.0 ltr

Auxiliary hydraulic system

SH130-6			
Auxiliary piping type (option)	For Breaker	For Double (breaker & crusher) acting	For D/A + Second option line
Arm type	STD	HD	HD
Bucket linkage type	HD	HD	HD
Auxiliary hydraulic pump flow	129 ltr/min	258 ltr/min	258+54 ltr/min

Bucket

Options and specifications may differ depending on countries and regions

Model		SH130-6								
Bucket capacity (ISO/SAE/PCSA heaped)		0.24 m ³	0.30 m ³	0.45 m ³	0.45 m ³	0.50 m ³	0.50 m ³	0.55 m ³	0.55 m ³	0.65 m ³
	Bucket capacity (CECE heaped)	0.22 m ³	0.28 m ³	0.40 m ³	0.40 m ³	0.45 m ³	0.45 m ³	0.50 m ³	0.50 m ³	0.60 m ³
Bucket type		STD	STD	STD	STD Horizontal-pin	STD	STD Horizontal-pin	STD	STD Horizontal-pin	STD
Number of teeth		4	4	4	4	5	5	5	5	5
Width unit: mm	With side cutter	582	692	907	907	972	972	1057	1057	1192
	Without side cutter	508	618	833	833	898	898	983	983	1118
Weight unit: kg		285	322	368	352	395	375	411	394	445
	2.11 m arm	○	○	○	○	○	○	●	●	○
	2.50 m arm	○	○	○	○	●	●	○	○	×
Combination	3.01 m arm	○	○	○	○	×	×	×	×	×

○ Suitable for materials with density up to 2,000 kg/m³ or less

○ Suitable for materials with density up to 1,600 kg/m³ or less

● Standard bucket (Suitable for materials with density up to 1,800 kg/m³ or less)

× Not available

Weight & Ground Pressure

Model		SH130-6			
Shoe type		Shoe width	Overall width	Operating weight	Ground pressure
Triple grouser shoe		500 mm	2 490 mm	12 400 kg	40 kPa
		600 mm	2 590 mm	12 600 kg	34 kPa
		700 mm	2 690 mm	12 900 kg	30 kPa

Model		SH130LC-6			
Shoe type		Shoe width	Overall width	Operating weight	Ground pressure
Triple grouser shoe		500 mm	2 490 mm	12 700 kg	38 kPa
		600 mm	2 590 mm	12 900 kg	32 kPa
		700 mm	2 690 mm	13 200 kg	28 kPa

Model		SH130-6 Blade			
Shoe type		Shoe width	Overall width	Operating weight	Ground pressure
Triple grouser shoe		500 mm	2 490 mm	13 300 kg	43 kPa
		600 mm	2 590 mm	13 500 kg	36 kPa
		700 mm	2 690 mm	13 900 kg	32 kPa

Digging Force

Model		SH130-6		
Arm length		2.11 m (w/ power boost)	2.50 m (w/ power boost)	3.01 m (w/ power boost)
Bucket digging force (with auto power up)	ISO 6015	90 kN (95 kN)	90 kN (95 kN)	90 kN (95 kN)
	SAE: PCSA	80 kN (85 kN)	80 kN (85 kN)	80 kN (85 kN)
Arm digging force (with auto power up)	ISO 6015	70 kN (74 kN)	62 kN (66 kN)	56 kN (60 kN)
	SAE: PCSA	68 kN (72 kN)	60 kN (64 kN)	55 kN (58 kN)

Lifting Capacity

Notes: 1. Ratings are based on ISO 10567

- Lifting capacity does not exceed 75% of tipping load with the machine on firm, level ground or 87% full hydraulic capacity.
- The load point is a hook (not standard equipment) located on the back of the bucket.
- *Indicates load limited by hydraulic capacity.
- 0 m = Ground.



A: Radius of load
B: Bucket hook height
C: Lifting capacity



Unit: kg

SH130-6

UNDERCARRIAGE : STD BOOM : 4.63 (m) SHOE : 500 (mm)G BUCKET : SAE/PCSA 0.50 (m³) ARM LENGTH = 2.50 (m) MAXIMUM REACH = 8.31 (m) BLADE : -

Bucket Hook Height	Max. Radius		8 m		7 m		6 m		5 m		4 m		3 m		2 m		1 m		Min. Radius			
	(kg)	(m)	(kg)	(m)	(kg)	(m)	(kg)	(m)	(kg)	(m)	(kg)	(m)	(kg)	(m)	(kg)	(m)	(kg)	(m)	(kg)	(m)		
7 m	1340*	5.82	1340*	5.82					2380*	2380*									2040*	4.39	2040*	4.39
6 m	1220*	6.70	1220*	6.70				2390*	2110	2690*	2690*								2650*	4.55	2650*	4.55
5 m	1160*	7.30	1160*	7.30			1970*	1550	2650*	2090	2810*	2800							2730*	4.42	2730*	4.42
4 m	1150*	7.70	1150*	7.70			2130	1530	2810	2040	3090*	2810			3200*	3200*			2970*	3.62	2970*	3.62
3 m	1160*	7.94	1150	7.94			2090	1490	2740	1970	3680	2690	4320*	3880	5260*	5260*	6220*	6220*	5060*	1.53	5060*	1.53
2 m	1190*	8.03	1100	8.03	1330*	1110	2040	1440	2650	1890	3590	2560	5170	3670	6900*	5840			4850*	2.11	4850*	2.11
1 m	1250*	7.98	1100	7.98			1990	1400	2570	1820	3460	2440	4990	3450	8200*	5410			2790*	2.11	2790*	2.11
0 m	1360*	7.80	1130	7.80			1960	1360	2510	1760	3350	2340	4820	3300	7920	5170	3560*	3560*	2430*	1.48	2430*	1.48
-1 m	1520*	7.48	1210	7.48			1940	1340	2470	1720	3290	2280	4730	3220	7850	5130	4980*	4980*	3860*	0.34	3860*	0.34
-2 m	1770*	6.99	1360	6.99					2470	1720	3280	2280	4730	3230	7990	5160	6440*	6440*	5300*	0.23	5300*	0.23
-3 m	2190*	6.31	1620	6.31					2520	1780	3330*	2320	4780	3280	8050	5240	9000*	9000*	6590*	0.44	6590*	0.44
-4 m	3030	5.36	2130	5.36							3420*	2430	4870	3390	7410*	5390	10500*	10500*	8480*	1.09	8480*	1.09

SH130-6

UNDERCARRIAGE : STD BOOM : 4.63 (m) SHOE : 500 (mm)G BUCKET : SAE/PCSA 0.45 (m³) ARM LENGTH = 3.01 (m) MAXIMUM REACH = 8.77 (m) BLADE : -

Bucket Hook Height	Max. Radius		8 m		7 m		6 m		5 m		4 m		3 m		2 m		1 m		0 m		Min. Radius			
	(kg)	(m)	(kg)	(m)	(kg)	(m)	(kg)	(m)	(kg)	(m)	(kg)	(m)	(kg)	(m)	(kg)	(m)	(kg)	(m)	(kg)	(m)	(kg)	(m)		
8 m	1460*	5.32	1460*	5.32																	1700*	1700*		
7 m	1280*	6.47	1280*	6.47					1950*	1950*	2200*	2200*									2220*	4.90	2220*	4.90
6 m	1180*	7.26	1180*	7.26				1690*	1590	2230*	2160										2300*	5.05	2300*	5.05
5 m	1140*	7.81	1140*	7.81			2190	1590	2540*	2140	2370*	2370*									2350*	4.94	2350*	4.94
4 m	1120*	8.18	1110	8.18	1590*	1180	2170	1560	2690*	2090	2670*	2670*									2640*	4.48	2640*	4.48
3 m	1130*	8.40	1030	8.40	1650	1160	2120	1510	2780	2010	3310*	2760	3460*	3460*							2990*	3.18	2990*	3.18
2 m	1170*	8.49	990	8.49	1620	1130	2060	1460	2690	1920	3650	2610	4800*	3770	5760*	5760*					4020*	2.06	4020*	2.06
1 m	1230*	8.45	980	8.45	1590	1090	2000	1400	2590	1830	3500	2470	5070	3520	7570*	5560					3690*	2.05	3690*	2.05
0 m	1330*	8.28	1000	8.28	1560	1070	1950	1360	2510	1760	3370	2350	4850	3320	8070	5210	3750*	3750*			2440*	1.40	2440*	1.40
-1 m	1470*	7.97	1070	7.97			1920	1330	2450	1710	3280	2270	4710	3200	7840	5070	4740*	4740*	3380*	3380*	3030*	0	3030*	0
-2 m	1690*	7.52	1180	7.52			1910	1320	2430	1680	3250	2240	4680	3180	7900	5080	5950*	5950*	4740*	4740*	4330*	0	4330*	0
-3 m	1980	6.89	1370	6.89			2460	1710	3270	2260	4710	3210	7950	5140	7680*	5140	7680*	7680*	5940*	5940*	5030*	0	5030*	0
-4 m	2470	6.03	1720	6.03					2510	1750	3350	2340	4790	3290	7950	5250	10670*	10670*	7660*	7660*		0.43	6380*	0.43
-5 m	3420*	4.86	2470	4.86									4780*	3400	6480*	5400	9240*	9240*			11370*	1.55	11370*	1.55

SH130-6

UNDERCARRIAGE : LC BOOM : 4.63 (m) SHOE : 500 (mm)G BUCKET : SAE/PCSA 0.50 (m³) ARM LENGTH = 2.50 (m) MAXIMUM REACH = 8.31 (m) BLADE : -

Bucket Hook Height	Max. Radius		8 m		7 m		6 m		5 m		4 m		3 m		2 m		1 m		Min. Radius					
	(kg)	(m)	(kg)	(m)	(kg)	(m)	(kg)	(m)	(kg)	(m)	(kg)	(m)	(kg)	(m)	(kg)	(m)	(kg)	(m)	(kg)	(m)				
7 m	1340*	5.82	1340*	5.82					2380*	2380*											2040*	4.39	2040*	4.39
6 m	1220*	6.70	1220*	6.70				2390*	2150	2690*	2690*										2650*	4.55	2650*	4.55
5 m	1160*	7.30	1160*	7.30			1970*	1580	2650*	2140	2810*	2810*									2730*	4.42	2730*	4.42
4 m	1150*	7.70	1150*	7.70			2460	1570	3040*	2090	3090*	2860*	3200*	3200*							2970*	3.62	2970*	3.62
3 m	1160*	7.94	1160*	7.94			2420	1530	3150	2020	3700*	2750	4320*	3950	5260*	5260*	6220*	6220*			5060*	1.53	5060*	1.53
2 m	1190*	8.03	1140	8.03	1330*	1150	2370	1480	3070	1940	4140*	2620	5340*	3750	6900*	5960					4850*	2.11	4850*	2.11
1 m	1250*	7.98	1130	7.98			2320	1440	2990	1870	4030	2500	5860	3530	8200*	5530					2790*	2.11	2790*	2.11
0 m	1360*	7.80	1170	7.80			2280	1400	2920	1800	3920	2400	690	3380	7980*	5290	3560*	3560*			2430*	1.48	2430*	1.48
-1 m	1520*	7.48	1250	7.48			2260	1380	2880	1770	3850	2340	5590	3300	8550*	5250	4980*	4980*	3860*	3860*	2700*	0.34	2700*	0.34
-2 m	1770*	6.99	1400	6.99					2880	1770	3840	2340	5590	3300	9180*	5280	6440*	6440*	5300*	5300*	4020*	0.23	4020*	0.23
-3 m	2190*	6.31	1660	6.31					2930	1830	3880	2380	5640	3350	8570*	5360	9000*	9000*	6590*	6590*	5620*	0.44	5620*	0.44
-4 m	3100*	5.36	2180	5.36							3930	2490	5570*	3470	7410*	5500	10500*	10500*			8480*	1.09	8480*	1.09

Notes: 1. Ratings are based on ISO 10567

- Lifting capacity does not exceed 75% of tipping load with the machine on firm, level ground or 87% full hydraulic capacity.
- The load point is a hook (not standard equipment) located on the back of the bucket.
- *Indicates load limited by hydraulic capacity.
- 0 m = Ground.



A: Radius of load
B: Bucket hook height
C: Lifting capacity



Unit: kg

SH130-6

UNDERCARRIAGE : LC BOOM : 4.63 (m) SHOE : 500 (mm)G BUCKET : SAE/PCSA 0.45 (m³) ARM LENGTH = 3.01 (m) MAXIMUM REACH = 8.77 (m) BLADE : -

Bucket Hook Height	Max. Radius		8 m		7 m		6 m		5 m		4 m		3 m		2 m		1 m		0 m		Min. Radius			
	(kg)	(m)	(kg)	(m)	(kg)	(m)	(kg)	(m)	(kg)	(m)	(kg)	(m)	(kg)	(m)	(kg)	(m)	(kg)	(m)	(kg)	(m)	(kg)	(m)		
8 m	1460*	5.32	1460*	5.32																	1700*	1700*		
7 m	1280*	6.47	1280*	6.47					1950*	1950*	2200*	2200*									2220*	4.90	2220*	4.90
6 m	1180*	7.26	1180*	7.26				1690*	1630	2230*	2200*										2300*	5.05	2300*	5.05
5 m	1140*	7.81	1140*	7.81			2210*	1630	2540*	2190	2370*	2370*									2350*	4.94	2350*	4.94
4 m	1120*	8.18	1120*	8.18	1590*	1210	2490	1600	2690*	2140	2670*	2670*									2640*	4.48	2640*	4.48
3 m	1130*	8.40	1060	8.40	1920	1190	2450	1550	2980*	2060	3310*	2820	3460*	3460*							2990*	3.18	2990*	3.18
2 m	1170*	8.49	1020	8.49	1890	1160	2390	1500																

Lifting Capacity

Notes: 1. Ratings are based on ISO 10567

- Lifting capacity does not exceed 75% of tipping load with the machine on firm, level ground or 87% full hydraulic capacity.
- The load point is a hook (not standard equipment) located on the back of the bucket.
- *Indicates load limited by hydraulic capacity.
- 0 m = Ground.



A: Radius of load
B: Bucket hook height
C: Lifting capacity



Unit: kg

SH130-6

UNDERCARRIAGE : STD BOOM : 4.63 (m) SHOE : 600 (mm)G BUCKET : SAE/PCSA 0.50 (m³) ARM LENGTH = 2.50 (m) MAXIMUM REACH = 8.31 (m) BLADE : -

Bucket Hook Height	Radius of Load																							
	Max. Radius		8 m		7 m		6 m		5 m		4 m		3 m		2 m		1 m		Min. Radius					
	(kg)	(m)	(kg)	(m)	(kg)	(m)	(kg)	(m)	(kg)	(m)	(kg)	(m)	(kg)	(m)	(kg)	(m)	(kg)	(m)	(kg)	(m)	(kg)	(m)		
7 m	1340*	5.82	1340*	5.82						2380*	2380*									2040*	4.39	2040*	4.39	
6 m	1220*	6.70	1220*	6.70				2390*	2130	2690*	2690*									2650*	4.55	2650*	4.55	
5 m	1160*	7.30	1160*	7.30			1970*	1570	2650*	2120	2810*	2810*								2730*	4.42	2730*	4.42	
4 m	1150*	7.70	1150*	7.70			2160	1550	2840	2070	3090*	2840			3200*	3200*				2970*	3.62	2970*	3.62	
3 m	1160*	7.94	1160*	7.94			2120	1510	2780	2000	3700*	2730	4320*	3920	5260*	5260*	6220*	6220*		5060*	1.53	5060*	1.53	
2 m	1190*	8.03	1130	8.03	1330*	1140	2080	1470	2690	1920	3640	2600	5230	3720	6900*	5920				4850*	2.11	4850*	2.11	
1 m	1250*	7.98	1120	7.98			2030	1420	2610	1850	3510	2480	5070	3500	8200*	5480				2790*	2.11	2790*	2.11	
0 m	1360*	7.80	1150	7.80			1990	1390	2550	1790	3410	2380	4890	3350	7990*	5240	3560*	3560*		2430*	1.48	2430*	1.48	
-1 m	1520*	7.48	1230	7.48			1970	1370	2510	1750	3440	2380	4800	3270	7960	5200	4980*	4980*	3860*	3860*	2700*	0.34	2700*	0.34
-2 m	1770*	6.99	1380	6.99					2510	1750	3340	2320	4800	3270	8110	5240	6440*	6440*	5300*	5300*	4020*	0.23	4020*	0.23
-3 m	2190*	6.31	1650	6.31					2570	1810	3380	2360	4850	3330	8160	5320	9000*	9000*	6590*	6590*	5620*	0.44	5620*	0.44
-4 m	3070	5.36	2160	5.36							3460	2470	4930	3440	7410*	5460	10500*	10500*		8480*	1.09	8480*	1.09	

SH130-6

UNDERCARRIAGE : STD BOOM : 4.63 (m) SHOE : 600 (mm)G BUCKET : SAE/PCSA 0.45 (m³) ARM LENGTH = 3.01 (m) MAXIMUM REACH = 8.77 (m) BLADE : -

Bucket Hook Height	Radius of Load																									
	Max. Radius		8 m		7 m		6 m		5 m		4 m		3 m		2 m		1 m		0 m		Min. Radius					
	(kg)	(m)	(kg)	(m)	(kg)	(m)	(kg)	(m)	(kg)	(m)	(kg)	(m)	(kg)	(m)	(kg)	(m)	(kg)	(m)	(kg)	(m)	(kg)	(m)	(kg)	(m)		
8 m	1460*	5.32	1460*	5.32																	1700*	1700*	1580*	4.84	1580*	4.84
7 m	1280*	6.47	1280*	6.47						1950*	1950*	2200*	2200*								2220*	4.90	2220*	4.90		
6 m	1180*	7.26	1180*	7.26					1690*	1610	2230*	2190									2300*	5.05	2300*	5.05		
5 m	1140*	7.81	1140*	7.81					2210*	1610	2540*	2170	2370*	2370*							2350*	4.94	2350*	4.94		
4 m	1120*	8.18	1120*	8.18	1590*	1200	2200	1590	2690*	2120	2670*	2670*									2640*	4.48	2640*	4.48		
3 m	1130*	8.40	1050	8.40	1680	1180	2150	1540	2820*	2040	3310*	2790	3460*	3460*							2990*	3.18	2990*	3.18		
2 m	1170*	8.49	1010	8.49	1650	1150	2100	1480	2730	1950	3690	2650	4800*	3810	5760*	5760*					4020*	2.06	4020*	2.06		
1 m	1230*	8.45	1000	8.45	1610	1120	2040	1430	2630	1860	3550	2510	5150	3570	5750*	5630					3690*	2.05	3690*	2.05		
0 m	1330*	8.28	1020	8.28	1590	1090	1990	1380	2550	1790	3420	2390	4920	3370	8180	5290	3750*	3750*			2440*	1.40	2440*	1.40		
-1 m	1470*	7.97	1090	7.97				1950	1360	2500	1740	3330	2310	4790	3250	7950	5150	4740*	4740*	3380*	3380*	3030*	0	3030*	0	
-2 m	1690*	7.52	1200	7.52				1950	1340	2470	1710	3300	2280	4750	3230	8010	5150	5950*	5950*	4740*	4740*	4330*	0	4330*	0	
-3 m	2020	6.89	1400	6.89					2500	1740	3320	2300	4780	3260	8070	5210	7680*	7680*	5940*	5940*	5030*	0	5030*	0		
-4 m	2510	6.03	1750	6.03					2550	1780	3400	2380	4870	3340	8030*	5330	10670*	10670*	7660*	7660*			6380*	0.43	6380*	0.43
-5 m	3420*	4.86	2510	4.86									4780*	3450	6480*	5460	9240*	9240*			11370*	1.55	11370*	1.55		

SH130-6

UNDERCARRIAGE : LC BOOM : 4.63 (m) SHOE : 600 (mm)G BUCKET : SAE/PCSA 0.50 (m³) ARM LENGTH = 2.50 (m) MAXIMUM REACH = 8.31 (m) BLADE : -

Bucket Hook Height	Radius of Load																									
	Max. Radius		8 m		7 m		6 m		5 m		4 m		3 m		2 m		1 m		Min. Radius							
	(kg)	(m)	(kg)	(m)	(kg)	(m)	(kg)	(m)	(kg)	(m)	(kg)	(m)	(kg)	(m)	(kg)	(m)	(kg)	(m)	(kg)	(m)	(kg)	(m)	(kg)	(m)		
7 m	1360*	5.82	1360*	5.82																	2400*	2400*	2200*	4.39	2200*	4.39
6 m	1240*	6.70	1240*	6.70						2400*	2200	2720*	2720*								2670*	4.55	2670*	4.55		
5 m	1180*	7.30	1180*	7.30						1990*	1620	2680*	2180	2820*	2820*						2750*	4.42	2750*	4.42		
4 m	1170*	7.70	1170*	7.70					2510	1610	3050*	2140	3100*	2920	3200*	3200*					3000*	3.62	3000*	3.62		
3 m	1180*	7.94	1180*	7.94					2470	1570	3210	2070	3720*	2810	4350*	4020	5300*	5300*	6350*	6350*			5200*	1.53	5200*	1.53
2 m	1220*	8.03	1170	8.03	1350*	1180	2420	1520	3140	1990	4220	2680	5380*	3820	6920*	6060					4910*	2.11	4910*	2.11		
1 m	1280*	7.98	1160	7.98			2370	1480	3050	1910	4110	2550	5950*	3600	8210*	5610					2830*	2.11	2830*	2.11		
0 m	1390*	7.80	1200	7.80			2340	1440	2990	1850	4000	2460	5790	3440	8030*	5380	3600*	3600*			2460*	1.48	2460*	1.48		
-1 m	1550*	7.48	1280	7.48			2310	1420	2950	1820	3930	2400	5710	3380	8610*	5370	5050*	5050*	3890*	3890*	2730*	0.34	2730*	0.34		
-2 m	1810*	6.99	1440	6.99					2940	1810	3930	2400	5710	3390	9180*	5400	6500*	6500*	5390*	5390*	4060*	0.23	4060*	0.23		
-3 m	2240*	6.31	1710	6.31					2990	1870	3970	2440	5760	3440	8560*	5480	8970*	8970*	6640*	6640*	5650*	0.44	5650*	0.44		
-4 m	3160*	5.36	2240	5.36									4000	2550	5570*	3550	7410*	5630	10480*	10480*			8510*	1.09	8510*	1.09

Notes: 1. Ratings are based on ISO 10567

- Lifting capacity does not exceed 75% of tipping load with the machine on firm, level ground or 87% full hydraulic capacity.
- The load point is a hook (not standard equipment) located on the back of the bucket.
- *Indicates load limited by hydraulic capacity.
- 0 m = Ground.



A: Radius of load
B: Bucket hook height
C: Lifting capacity



Unit: kg

SH130-6

UNDERCARRIAGE : LC BOOM : 4.63 (m) SHOE : 600 (mm)G BUCKET : SAE/PCSA 0.45 (m³) ARM LENGTH = 3.01 (m) MAXIMUM REACH = 8.77 (m) BLADE : -

Bucket Hook Height	Radius of Load																										
	Max. Radius		8 m		7 m		6 m		5 m		4 m		3 m		2 m		1 m		0 m		Min. Radius						
	(kg)	(m)	(kg)	(m)	(kg)	(m)	(kg)	(m)	(kg)	(m)	(kg)	(m)	(kg)	(m)	(kg)	(m)	(kg)	(m)	(kg)	(m)	(kg)	(m)	(kg)	(m)			
8 m	1460*	5.32	1460*	5.32																		1700*	1700*	1580*	4.84	1580*	4.84
7 m	1280*	6.47	1280*	6.47									1950*	1950*	2200*	2200*							2220*	4.90	2220*	4.90	
6 m	1180*	7.26	1180*	7.26									1690*	1650	2230*	2230*							2300*	5.05	2300*	5.05	
5 m	1140*	7.81	1140*	7.81									2210*	1650	2540*	2220	2370*	2370*					2350*	4.94	2350*	4.94	
4 m	1120*	8.18	1120*	8.18	1590*	1230	2520*	1630	2690*	2170	2670*	2670*											2640*	4.48	2640*	4.48	
3 m	1130*	8.40	1080	8.40	1950	1210	2490	1580	2980*	2090	3310*	2850	3460*	3460*									2990*	3.18	2990*	3.18	
2 m	1170*	8.49	1040	8.49	1920	1180	2430	1520	3150	2000	3950*	2710	4800*	3900	5760*	5760*					4020*	2.06	4020*	2.06			
1 m	1230*	8.45	1030	8.45	1890	1150	2370	1470	3060	1910	4130	2570	5760*	3650	7570*	5750					3690*	2.05	3690*	2.05			
0 m	1330*	8.28	1060	8.28	1860	1120	2320	1420	2970	1840	4000	2450	5810	3450	8580*	5410	3750*	3750*			2440*	1.40	2440*	1.40			
-1 m	1470*	7.97	1120	7.97					2280	1390	2920	1780	3900	2370	5670												

Principle Specifications

		SH130-6
		STD Specifications
Base	Boom length	4.63 m
	Arm length	2.50 m
	Bucket capacity (ISO heaped)	0.50 m ³
	Std. operating weight	12,400 kg
Engine	Make & model	ISUZU GJ-4JJ1X
	Rated output	70.9 kW (96.4 PS)/2,000 min ⁻¹
Hydraulic System	Displacement	2.99 ltr
	Main pump	2 variable displacement axial piston pumps with regulating system
	Max pressure	34.3 MPa
	(with auto power boost)	36.3 MPa
	Travel motor	Variable displacement axial piston motor
Performance	Parking brake type	Mechanical disc brake
	Swing motor	Fixed displacement axial piston motor
Performance	Travel speed	5.6/3.4 km/h
	Drawbar pull	116.0 kN
	Gradeability	70% <35°>
	Ground pressure	43 kPa
	Swing speed	14.1 min ⁻¹
	Bucket digging force	90.0 kN
Others	/with power boost	95.0 kN
	Arm digging force	62.0 kN
	/with power boost	66.0 kN
	Fuel tank	260 ltr
Hydraulic fluid tank	82 ltr	

Standard Equipment

[Hydraulic system]

- SIH:S+ hydraulic system
- Operation mode (SP, H and A mode)
- Automatic 2-speed travel
- Automatic power boost
- Arm/boom/bucket reactivation circuit
- Automatic swing parking system
- High-performance return filter

[Cabin/interior equipment]

- Strengthened cabin
- Top guard OPG level1 (in cab structure)
- 4-point fluid mounts
- Built-in type full-colour monitor display
- Tilting console
- Open air introducing pressurised full-automatic air conditioner
- Defroster
- Hot & cool box
- Seat suspension
- Windscreen wiper (with intermittent operation function)
- Cup holder
- AM/FM radio (with muting function and AUX port & USB port)
- Radio mute/ Windscreen wiper one-touch control on joystick
- Clock
- Magazine rack
- Accessory case
- Floor mat
- Armrest & headrest
- Ashtray & cigarette lighter
- Cab light (Auto-OFF function)
- Coat hook

[Safety equipment]

- Rearview mirror (left/right)
- Emergency escape tool
- Retracting seat belt
- Gate lock lever
- Travel alarm (with on and off switch)
- Anti-theft alarm system
- Engine room firewall
- Fan guard
- Engine emergency stop switch
- Engine neutral start

[Others]

- Auto/one-touch idling
- Auto idle shutdown system
- EMS
- Long-life hydraulic oil
- Two lights (main unit and left of boom)
- Fuel filter (with water separator)
- Fuel prefilter (with water separator)
- Double-element air cleaner
- Grease-enclosed track link
- Large tool box
- A set of tools

Accessories (option)

■ Cab-top lights



■ Rain deflector



■ 12V power (DC-DC converter)



■ Head guard (OPG level 2)



■ Polycarbonate roof top window with sunshade



■ Front guard (OPG level 1 or 2)



■ Front mesh guard (full/lower)



■ Precleaner



■ Air suspension (KAB seat)



■ Blade



■ Refuel pump

■ Hose burst check valve (HBCV) for boom/arm cylinders

■ Rear view camera

■ Side camera

■ ROPS Cabin

■ ISO compliant mirror

Working Range

		SH130(LC)-6		
Arm length		2.11 m	2.50 m	3.01 m
Boom length			4.63 m	
A Max digging radius		7 960 mm	8 310 mm	8 770 mm
B Max digging depth		5 150 mm	5 540 mm	6 050 mm
C Max digging height		8 550 mm	8 770 mm	9 050 mm
D Max dumping height		6 170 mm	6 390 mm	6 680 mm
E Max vertical wall cut depth		4 600 mm	4 950 mm	5 350 mm
F Min front swing radius		2 360 mm	2 340 mm	2 660 mm
G Rear end swing radius			2 130 mm	
H Max. lift above ground			515 mm	
I Min. drop below ground			520 mm	

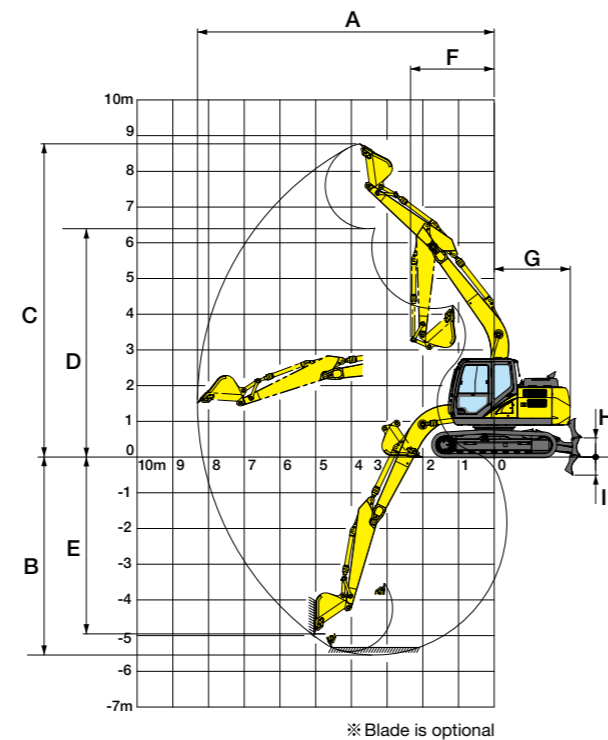

Accessories and specifications may differ depending on countries and regions.

Dimensions

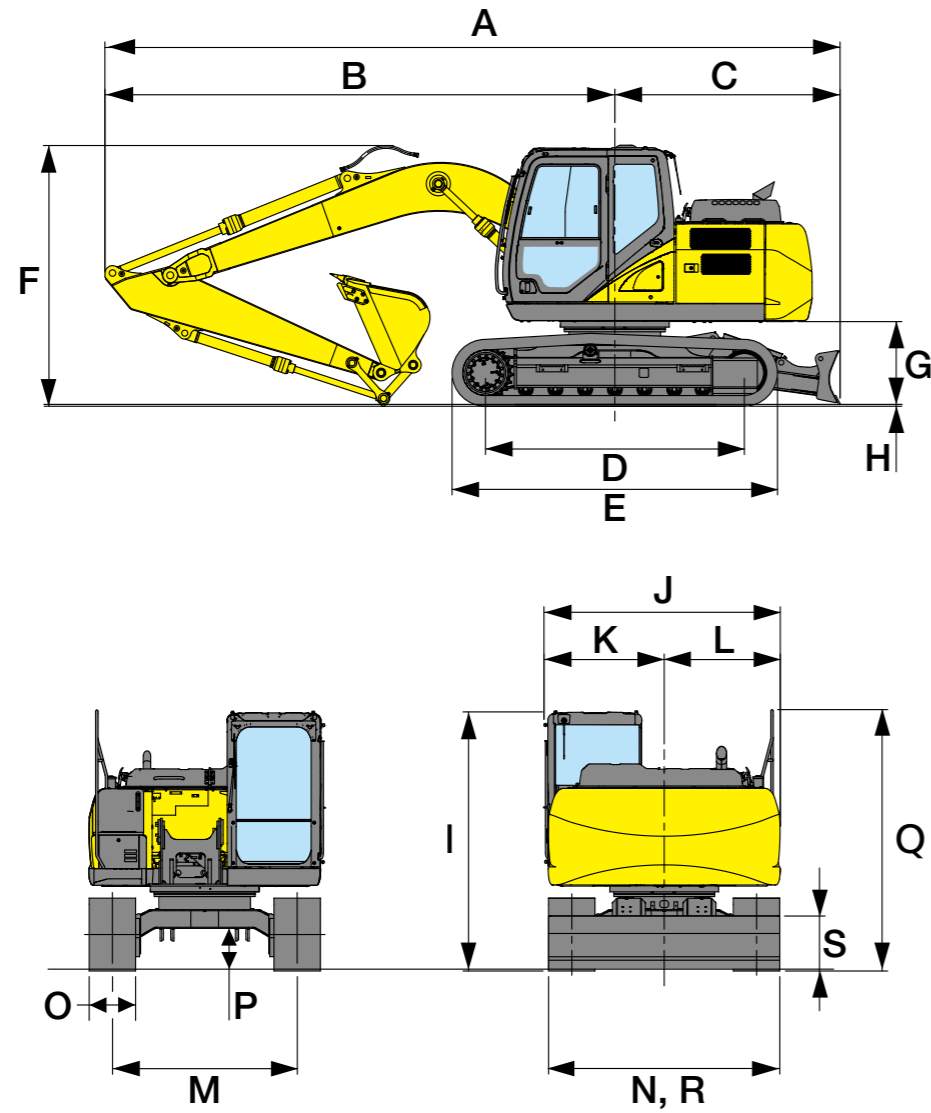

MEMO

Model	SH130(LC)-6		
Arm length	2.11 m	2.50 m	3.01 m
A Overall length	7 610 mm	7 620 mm	7 640 mm
(equipped with blade)	7 910 mm	7 920 mm	7 940 mm
B Length from centre of machine (to arm top)	5 480 mm	5 490 mm	5 510 mm
C Length from centre of machine (to blade)		2 430 mm	
D Centre to centre of wheels		2 790 (3 040) mm	
E Overall track length		3 500 (3 760) mm	
F Overall height (to top of boom)	2 710 mm	2 810 mm	2 820 mm
G Clearance height under upper structure		890 mm	
H Shoe lug height		20 mm	
I Overall height (to top of cab)		2 790 mm	
J Upper structure overall width		2 540 mm	
K Width from centre of machine (left side)		1 290 mm	
L Width from centre of machine (right side)		1 250 mm	
M Track gauge		1 990 mm	
N Overall track width		2 490 mm	
O Std. shoe width		500 mm	
P Minimum ground clearance		440 mm	
Q Overall height (to top of handrail)		2 820 mm	
R Width of blade		2 490 mm	
S Height of blade		570 mm	

Figure in () : LC type ※For 3.01 m arm — Arm cylinder pin at transportation point.