



# LEADERS IN FLEXIBILITY.

THE RS 460 AND RS 500 SOIL STABILIZERS/RECYCLERS.





# MILLIONS OF KILOMETRES BEAR OUR SIGNATURE.

Any contractor involved in building roads, landscaping, or other earthworks projects needs to be able to do one thing above all: compact. And to help you achieve the best results, we build the best machines. For over 60 years, our company has helped write road construction and compaction technology history.

With our cumulative expertise, we have also set the pace for the entire soil stabilizer and recycler product sector. We have increased the utilisation of these machines with multiple new technologies. This protects resources and the environment and increases productivity. It also delivers faster construction completion times.

Our specialists working around the world and our partners in more than 120 countries are on hand to support you, from the fitting out of machines to solving the most demanding challenges.

We owe our power of innovation to more than 2,500 committed employees worldwide. This expertise has made us the world market leader in compaction. Driven by our unconditional commitment to quality: during product development and production, in training our employees, and in providing a level of service which guarantees only the best on site support.









# THE RIGHT SOLUTION FOR EVERY CONSTRUCTION SITE.

Choosing BOMAG means choosing expertise, quality and efficiency. A choice of size or power, with 360 or 950 PS, BOMAG soil stabilizers and recyclers will handle every construction site to perfection. From car parks, roads, landfill sites and dam construction to industrial areas, major highways, railway tracks and airports – BOMAG recyclers are used on a wide variety of applications. Our unique, global product range are designed for varied fields

of application such as crushing asphalt, soil stabilisation, or cold recycling. Our experienced international team of specialists ensure that we meet the requirements of every construction site and continuously innovate and lead.

Our engineers' skills and expertise work for you to deliver top performance and reliability.



RS 460 (top) and RS 500 (bottom).









# DETAILS AND FEATURES.

## THE RS 500.

### EASY MAINTENANCE

- Wide-opening engine hood for easy work



### HIGHER EFFICIENCY AND LOWER MAINTENANCE

- Hydraulic-mechanical rotor drive



## MAXIMUM SAFETY WITH OUTSTANDING ALL-ROUND VISIBILITY

- ROPS/FOPS cab as standard
- Large windows for excellent all-round visibility

## OUTSTANDING MIXING RESULTS

- FLEXMIX for highest quality combined with lower costs

## HIGH QUALITY AND SAFETY

- The lateral sliding rotor on the RS 500 allows safe working on slopes and lane edges

## POWERFUL TRACTION

- Four wheel motors with two travel pumps for maximum forward drive







ANOTHER BOMAG ADVANTAGE:  
LATERAL SLIDING ROTOR (RS 500).

## SAFER. ON EVERY SIDE.

To work safely on slopes, the milling and mixing rotor can be moved over the wheel edge on the left and right side. The drive wheels remain on more solid ground.

For the first time, a machine which can plane up to the edge of a slope without risk. The excellent view to the outer edges of the rotor hood allows the RS 500 to be manoeuvred with precision.



Manoeuvring safely, working neatly – with the sliding milling rotor.



## QUALITY CLOSE UP TO THE EDGE.

The sliding rotor with 30 cm extension width ensures more quality and safety on diverse construction projects. With a zero side to the left and right, soils in road construction, earthworks, and dam construction can be mixed right up to the edge. This ensures stability and prevents soil displacement. Soil can be stabilised up to existing materials – important, for example, when widening roads. And here is another advantage of the BOMAG rotor which can be slid left or right: in confined areas with joint edges on both

sides, the machine needs a quick reset, the rotor slid to the other side, and work can recommence. Turning which takes time and costs money is no longer necessary.

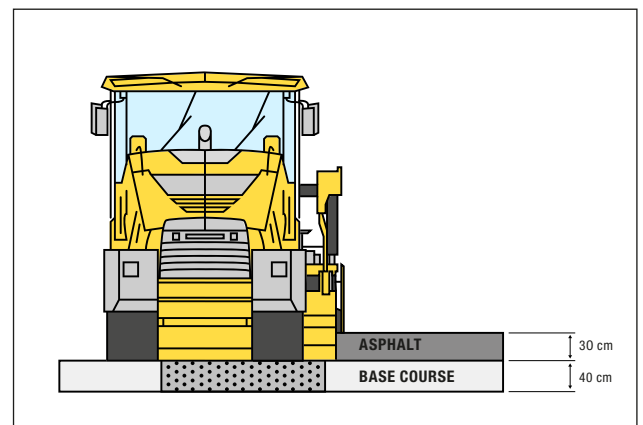



KEY BOMAG ADVANTAGE:  
FLEXMIX TECHNOLOGY (RS 500).

## NOTHING MIXES AND CRUSHES BETTER.

Unique from BOMAG: There are three infinitely adjustable gates on the rotor hood. Apart from the standard configuration options, BOMAG offers additional mixing and a crushing gate in the rotor hood. If required, the planed material is reduced to the specified size by the mixing bar. In-

finite, variable adjustment of all three gates means any specified result is achieved easily and safely. For maximum mixing output and top quality, BOMAG FLEXMIX technology always has the right configuration option.

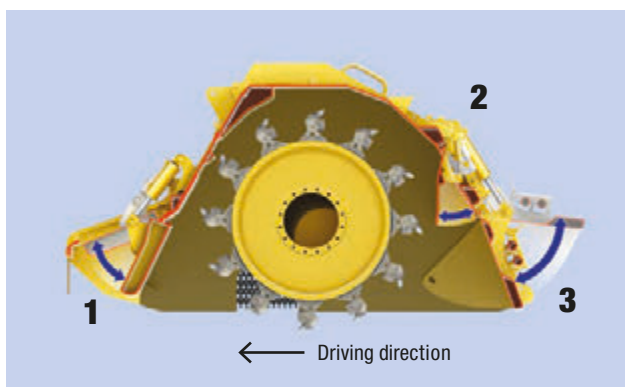

- 1 Front and crusher gate
- 2 Mixing and crushing gate
- 3 Rear and distancing gate





# POWERFUL IN BOTH DIRECTIONS.

Precision is not a one-sided affair with Flexmix technology. Crushing asphalt and mixing soils and binders in forward direction.



This is a major advantage in confined site conditions or on extremely soft soil. Simply turn the seat and set the direction of travel. All travel lever functions are maintained: right remains right and left remains left – no need to re-think.

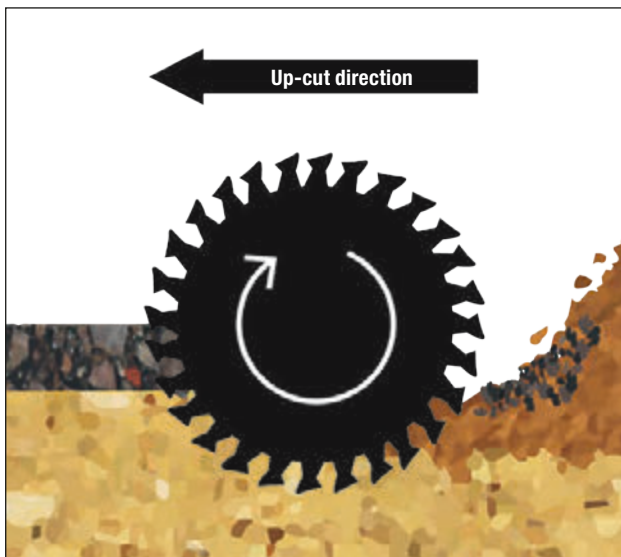

**Up-cut direction:** Pulverising asphalt from beneath.

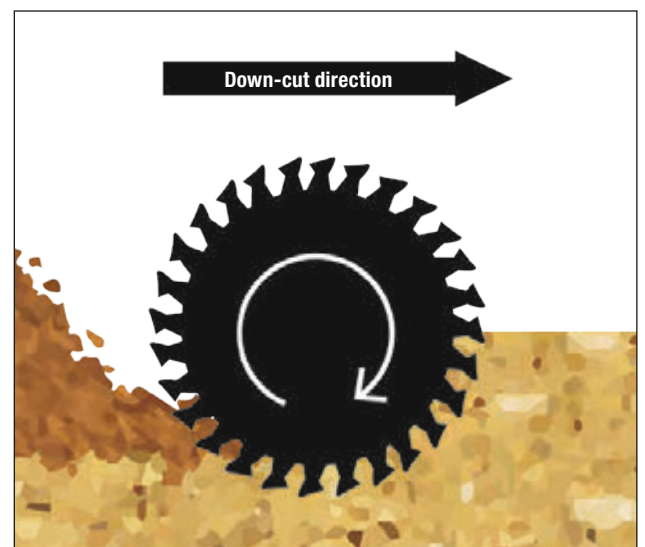

**Down-cut direction:** mixing soils from above – the rotor drive assists travel in the process.



# DETAILS AND FEATURES.

## THE RS 460.

### EASY MAINTENANCE

- Wide-opening engine hood for easy maintenance work



### GREATER EFFICIENCY AND LESS MAINTENANCE

- Hydraulic-mechanical rotor drive

## MAXIMUM SAFETY WITH OUTSTANDING ALL-ROUND VISIBILITY

- ROPS/FOPS cab as standard
- Large windows for excellent all-round visibility

## MAXIMUM RANGE

- High capacity fuel tanks for long working shifts



## POWERFUL TRACTION

- Three hydraulic motors, two single front drives, and a non-spin rear axle make for effortless forward drive



## BOMAG DRIVE TECHNOLOGY.

# POWERFUL, RELIABLE, AND COST-EFFECTIVE: THE TRAVEL SYSTEM.

The drives in our new soil stabilizers and recyclers put you ahead of the rest. Not only from a technical point of view, but also to cut costs. For the driver of a RS 460 or RS 500 one thing is certain: Power. The permanent 4x4 all-wheel drive can handle all conditions. Other features impress too.

### RS 460:

- 1 pump and 3 drive motors
- Non-spin rear axle
- Anti Spin Control (ASC)

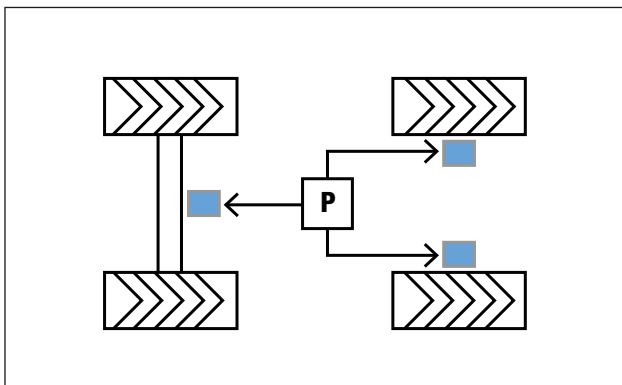

### RS 500:

- 2 mechanically coupled pumps
- 4 drive motors
- Flow divider left/right
- Most powerful travel system on the market

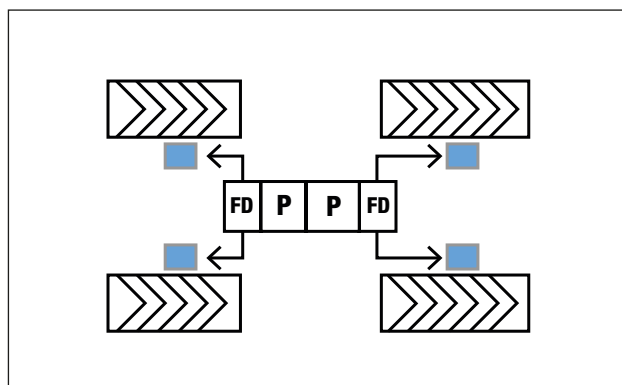

Large wheels for low ground contact pressure.



Non-spin oscillating axle  $\pm 15^\circ$  (RS 460).



Rear axle with powerful single drives (RS 500).

# HYDROSTATIC ROTOR DRIVE.

RS 460 and RS 500 are equipped with a hydrostatic rotor drive. The rotor speed can be continuously varied from the driver's seat. This guarantees the best mix quality with low wear and less fuel consumption.

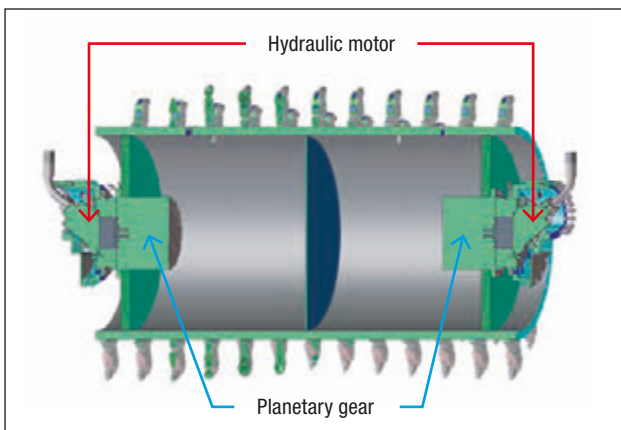

Wear and maintenance-free rotor drive.



Key feature: the hydrostatic overload protection system. This is automatically blocked if obstacles are encountered which could cause the drive to overload; for example, buried objects, old tramlines, or manhole covers. In the process, the pressure relief valves open, preventing damage to the mechanical gearbox.



The hydraulic overload protection system protects against unwanted "surprises".

## EFFICIENT ROTOR DRIVE.

A milling and mixing rotor driven by two planetary gear units provides maximum traction on all applications. In milling mode, the rotor speed is infinitely variable, which means tool and rotor wear can be kept to a minimum. By being able to adjust the rotor speed easily to a work situation, the best mixing result achieved with the least fuel consumption. The rotor automatic overload protection system also provides high machine availability on the toughest sites.

The hydraulic rotor drive is not liable to contamination as no debris and dirt can penetrate. What's more, it's maintenance-free.



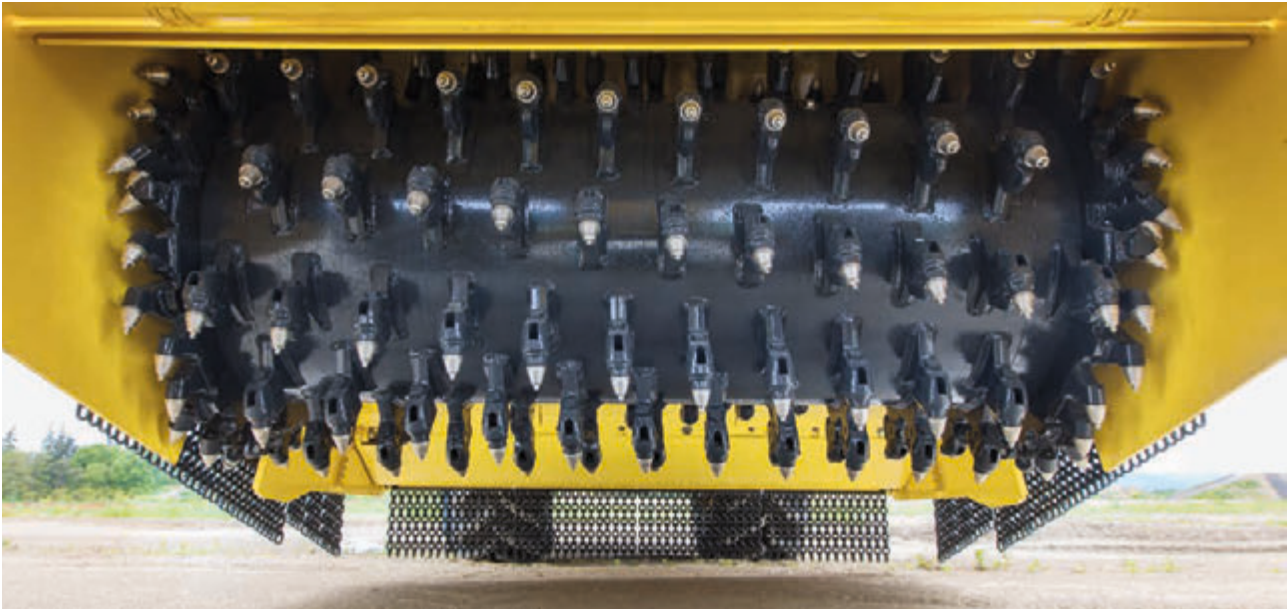

BOMAG universal rotor for all recycling and stabilisation work.

## BOMAG DRIVE TECHNOLOGY.

# AT THE CUTTING EDGE: THE ROTOR.

Low wear, excellent access and quick changing times for wear parts have set new standards for availability and productivity. The heavy weight provides maximum centrifugal mass for difficult pulverisation work.

### NEW STANDARD FOR TOOL HOLDERS.

Never compromise – the standard set for the development of the new BOMAG BRS 05 quick-change holder system. Increased cost-cutting plays a leading role. The system designed for use on soil stabilizers and recyclers ensures low costs and quick changing times, even on difficult site conditions. The positive connection between both elements guarantees safe operation even under maximum loads.

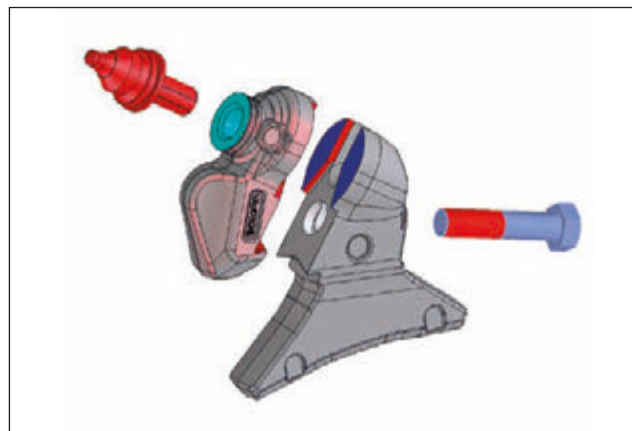

BOMAG BRS 05 quick-change holder system.

By request, the rotor can be fitted with a tool holder for a 20 mm shank cutting tool. This means tools from cold planers can also be used for higher cost cutting.

- Contamination-resistant design for easy handling
- Positive connection for safe operation
- Long service life with high wear-resistant steel

## CHANGE WEAR PARTS SAFELY AND FAST.

During a tool change, operator safety comes first. All wear parts can be changed quickly without risk. All machine functions can be deactivated with a tool change switch. The operator is able to turn the rotor in either direction using the electric-hydraulic rotary unit which comes as standard. In this case, the rotor hood is also secured to prevent lowering. Working headlights provide ample light under the rotor hood even with no daylight. The compressed air system which comes as standard allows the use of pneumatic tools, making daily maintenance work easier. To protect rotor edges, the rotor has four segments which can be individually exchanged without completely removal of the rotor. This saves time and money. And increases availability.

- Excellent access for changing holders and milling cutters
- Service switch and hood fixing device ensure operator safety
- Two directions of rotation on the rotor enable easy unwinding of lines, cables and wires
- Electric-hydraulic rotary unit as standard





## CONVENIENCE AND SAFETY.

# ERGONOMIC IN ANY WORK POSITION.

*Even the most sophisticated technology doesn't have to be complicated. RS 460 and RS 500 are testimonies to this.*

A symmetrically designed machine with the rotor placed centrally within the frame in the direction of travel allows work on the left and right milling edge. This requires an ergonomic working position for the operator on both sides. The ROPS-FOPS cab allows the workplace to be shifted within the cab. The seat can be turned 270° providing perfect ergonomics and healthy and fatigue-free work, even on long shifts. Large, protruding glass windows give an excellent overall view of work and stay clean in dusty en-

vironments. Regardless of the driver's seated position: all important control elements, including the two joysticks on the arm rests, are always in the same position. The driver is able to view all machine functions and settings and control the metering system on the clear display.



Ergonomic work position for fatigue-free work.



The screen displays and sets the metering systems.



The display is for displaying and setting only the metering systems.



## EVERYTHING IN SIGHT.

On busy sites, it is important to have everything in sight. The high-up work position of the cab and windows give a perfect view of the worked edges. This offers the best view around the machine and safe manoeuvring. The flexible rotation of the seat aids this.

The camera system provides additional safety in the RS 460 and RS 500. Two cameras provide a 180 degree view both to the left and right of the machine. They show live images on two monitors, which can readily be seen by the driver during forward and backward travel.

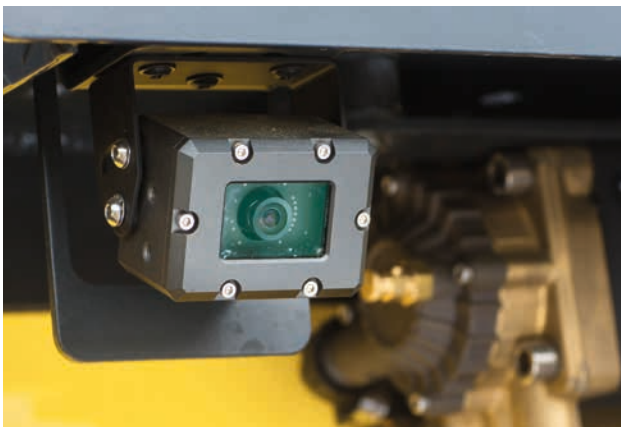

Perfect view even in reverse travel with the 270 degree rotating seat.





## MAINTENANCE AND SERVICE.

# MAINTENANCE-FREE INCLUDED.

*Choosing BOMAG is choosing top quality. This applies to maintenance and service too.*

The maintenance of these machines is as simple as their operation. Our basic principle this : the best maintenance is low maintenance. For example, there are separate compartments for the radiator and engine so dusty air cannot enter the engine compartment and contaminate the engine. If necessary, both fans can be reversed at the push of a button, blowing dust from the radiator.

The central lubrication system in the RS 500 (optional for the RS 460), which supplies lubrication points automati-



Standard in the RS 500: the central lubrication system.



Reversible fans for less cleaning and greater utilisation.

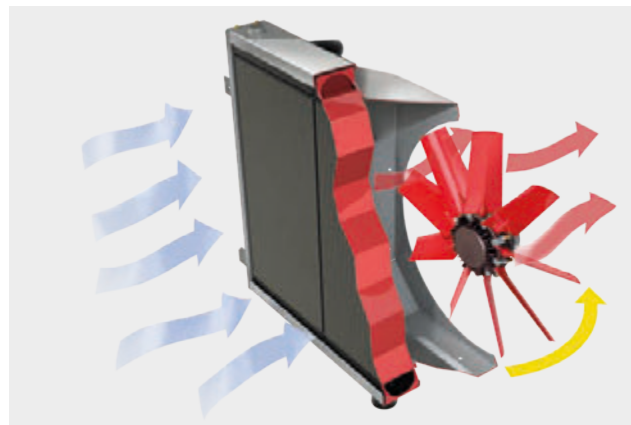



## GOOD ACCESS – JOB DONE.

The wide opening engine hood allows easy access to the radiator, and filter, etc. If necessary, the engine hood can be opened completely at the touch of a button. Large and easily accessible storage spaces make the transportation of wear parts easy. By the same token, access from the ground allows safe handling.

A high-pressure cleaner can help when things get really dirty. The large reserve water supply is sufficient for other machines on site.





The RS 500 easily fits on any standard low loader.

## BOMAG EFFICIENCY.

# FOR 100% FLEXIBILITY ON THE JOB.

*BOMAG offers many options to equip your RS 460 and RS 500 for a specific job.*



### NEW WAYS OF TRANSPORTATION.

For a one-day construction site or larger projects: the compact design of these new machines and the height adjustable ROPS/FOPS cab allow easy and fast transporta-

tion from site to site. In conjunction with great efficiency, operating costs per cubic metre are significantly reduced.

### BOMAG TELEMATIC.

The optional BOMAG TELEMATIC also provides efficient, transparent fleet management.

It means, for example, that you will know where machines are at all times, how they are being used, how high fuel consumption is, and when maintenance work is due. If necessary, error codes can be read using the teleservice and appropriate action taken.

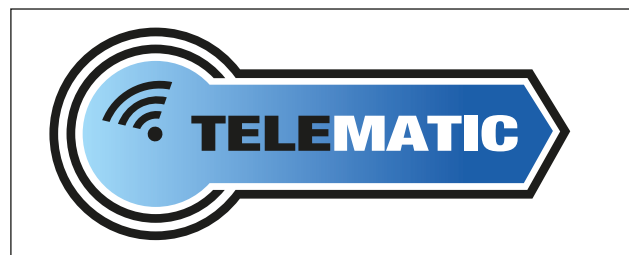

# JUST A LITTLE MORE?

## FILL UP FAST.

The RS 460 and RS 500 can be optionally equipped with the BOMAG Fast Refuel System. This allows 1,000 litres of fuel to be delivered into the tanks per minute. This saves time – and money.



## TOOLS

For crushing or stabilising, for asphalt, concrete, cohesive soils, or gravel: BOMAG has cutting tools for the RS 460 and RS 500 in various dimensions and hardness. They provide additional flexibility on the most varied construction sites.

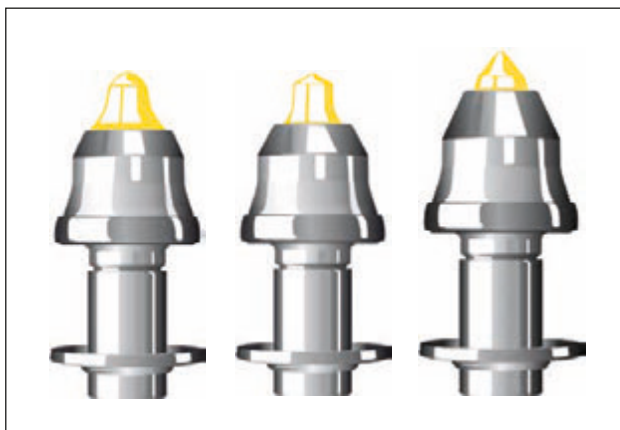

## SERVICE KITS.

We make it easy for you: everything you need for the maintenance of your machine is delivered in one useful package. BOMAG service kits are available individually for your machine. We've done the time-consuming assembly of the parts for you. You only need one order number for the parts you need in proven BOMAG quality. You won't lose time, you are safe from wrong deliveries, and your machine will be quickly ready for work again.



## SERVICE AT YOUR FINGER TIPS.

Are you looking for a spare part or the nearest BOMAG service partner? With the free BOMAG Service app you can quickly access spare parts lists, technical data, operating and maintenance instructions and videos – just enter your machine serial number. Download it now.





## BOMAG INJECTION SYSTEMS.

# ACCURATE DOSING, PERFECT RESULTS.

### WATER INJECTION SYSTEM.

The fully automatic water injection system ensures perfect water content in the soil. The performance: up to 900 litres a minute. This can also be extended (optional) by a second

pump connected in parallel to deliver 1,600 litres a minute. The clear graphics display provides the driver with an overview at all times.

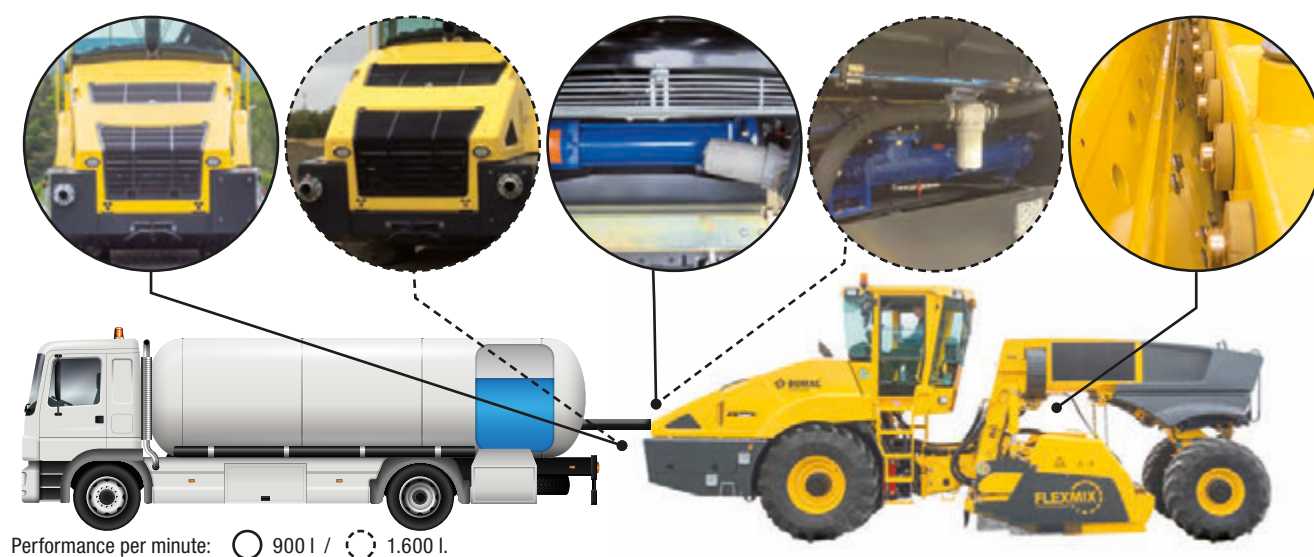

### PRINTER.

Using the metering computer, the injection data for the job can be recorded and printed out in the cab at the touch of a button. For example:

- Working mode
- Settings for water and bitumen
- Density



### WATER FILTER.

The water pre-filter is inserted in the 4" Perrot intake port of the water injection system. This allows coarse particles, which could block or damage the water pump, to be filtered out beforehand.



**BITUMEN EMULSION FILTER.**

If the water system is used for the bitumen emulsion, a special filter can be attached in front of the pump.

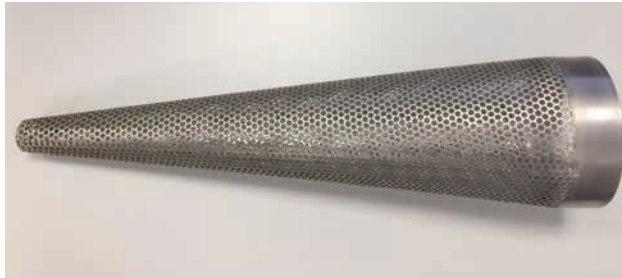
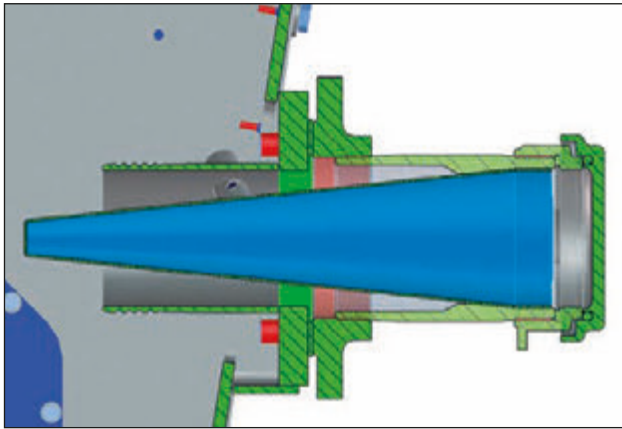

**BITUMEN EMULSION SYSTEM.**

Cold or up to 60 °C hot bitumen emulsion is injected and metered fully automatically by a hydraulically driven auger pump. The 16 nozzles in eight sections can be switched on and off in each section. If bitumen emulsion and water are added in the process, two precision pumps controlled by the metering computer operate separately from one another for the perfect result.

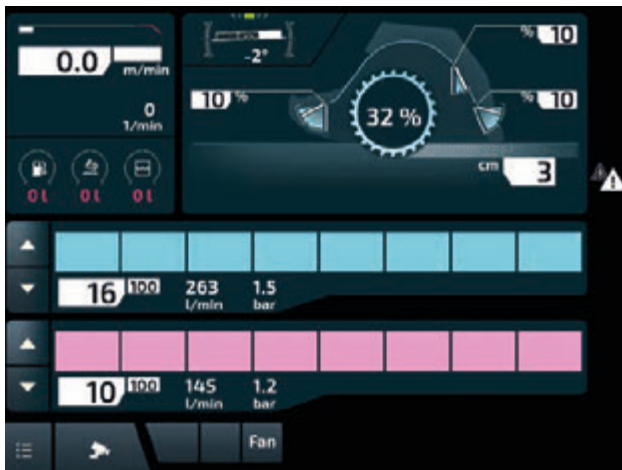

**CEMENT SUSPENSION SYSTEM.**

The mixing system, pushed by a bar by the recycler, pumps and meters the suspension through the pre-filter in the recycler. In the process, unwanted coarse particles are filtered out. The suspension is then conveyed to the spray bar by a total of 16 manually switchable nozzles. A cleaning lance can be used to easily clean the filter and spray bars.

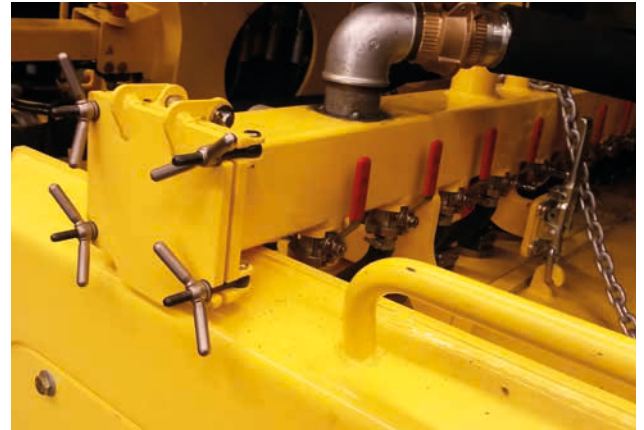

**BOMAG SMART DOSING.**

Permanently records work parameters, including those for metering. The system creates a WiFi network around the machine. Data is continuously transmitted to a mobile terminal device where it can be displayed without the need for special software.





BOMAG EXPERTISE.

## CONTINUING A TRADITION.

Over 40 years of experience in the development and manufacture of soil stabilizers and recyclers benefit our customers. Customer proximity, especially on construction sites, has produced ideas and innovations time and again. The same goes for the new RS 460 and RS 500. Many previously unresolved issues on construction sites involving risk have now become safe with the new generation of BOMAG recyclers.



Milling 8 cm of asphalt road.





Homogenisation of cohesive soils to a 50 cm depth.



Milling a hydraulically bound base course.



# MODEL OVERVIEW.



**RS 360**



**RS 460**



**RS 500**



**RS 600**



**RS 650**

<b>TIER 4 FINAL</b>	Engine output	Operating weight	Working width	Working depth
<b>RS 360</b>	261 kW	17,690 kg	2,005 mm	305 mm
<b>RS 460</b>	340 kW	24,150 kg	2,440 mm	500 mm
<b>RS 500</b>	380 kW	24,900 kg	2,250 mm	500 mm
<b>RS 650</b>	480 kW	27,900 kg	2,400/2,600 mm	600 mm

<b>TIER 3</b>	Engine output	Operating weight	Working width	Working depth
<b>RS 360</b>	268 kW	17,690 kg	2,005 mm	305 mm
<b>RS 460</b>	335 kW	24,150 kg	2,440 mm	500 mm
<b>RS 500</b>	375 kW	24,900 kg	2,250 mm	500 mm
<b>RS 600</b>	440 kW	27,900 kg	2,400/2,600 mm	600 mm

Technical modifications reserved. Machines may be shown with optional accessories.





**BOMAG**  
PNEUM GROUP

**RS500 II**



# POWER AND STABILITY FOR THE FUTURE.

Decades of experience, expertise and commitment to quality have made us who we are today: Leaders in compaction technology. Our clear focus: our customers. 100 percent performance in products and

services. With specific training courses, and personal on site support. Moving ahead with innovation. You and BOMAG – a successful team.

